

Portable External Pump for Gas Detector **G-Finder Pump (GFP-10)**

GFP-10 is portable external pump for gas detector used in an industrial area. With GFP-10 installed, diffusion type gas detector can be converted into sampling type gas detector



GASTRON DETECTOR

Portable External Pump for Gas Detector



G-Finder Pump (GFP-10)

Features

01 Conversion

Portable gas detector with GFP-10 can be used as sampling gas detector. It is used to detect gas in the area where users cannot reach. Also, GFP-10 can prevent accidents before users entering the confined area with additional accessory, probe.

02 Optimization

GFP-10 can be used under the various conditions with different combinations. As there are 3 different types, Stand-alone type, G-Finder Single type and G-Finder Multi type, GFP-10 can be applied on different site conditions including confined space and hazardous area with combustible gas.

03 User Friendly

GFP-10 can be operated with only one button. By pressing the button for more than 3 seconds will start the operation of the pump. The operation status can be easily checked by the LED indicator, which allows users to react on troubles of the pump in real time.

04 Charge

GFP-10 can be charged with USB Type-C cable. A full charge will take up to 7.5 hours, and can be operated more than 20 hours after the full charge.

05 Complete Structure of Explosion Proof

GFP-10 acquired Explosion Proof Certification including KCs (Korea), IECEx (International) and ATEX (Europe). It can be safely used in sites with combustible gases without secondary explosion.

Combination Type

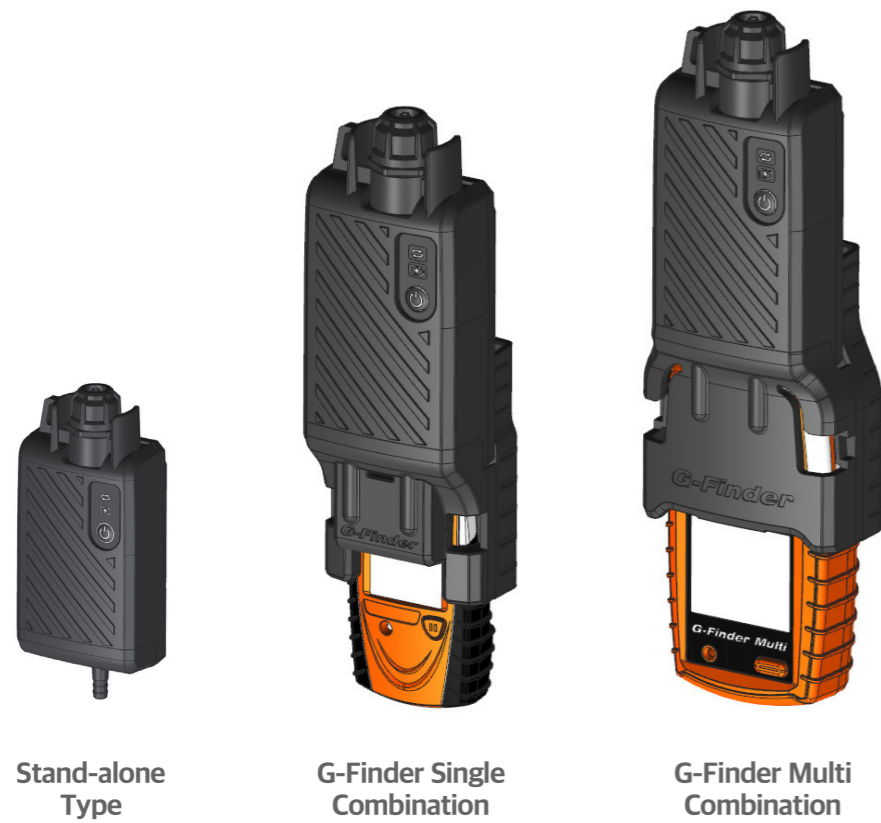

Stand-alone Type

Stand-alone type can be used without G-Finder Series connected to the pump. The air absorbed by the pump will be transferred through the hose connected to the bottom of the pump to connected detector for analyzing. The advantage of GFP-10 is that it can be connected to not only G-Finder Series, but to other brands portable detectors, as well as fixed type detectors within in 15m.

G-Finder Single Combination

G-Finder Single is a portable gas detector which can detect single gas of O₂ / H₂S / CO. If combined with GFP-10, it will convert into Sampling Single Channel Potable Gas Detector.

G-Finder Multi Combination

G-Finder Multi is a portable multi gas detector which can detect O₂ / H₂S / CO / Combustible gas simultaneously. If combined with GFP-10, it will convert into Sampling Multi Channel Potable Gas Detector.

Drawing

Stand-alone Type

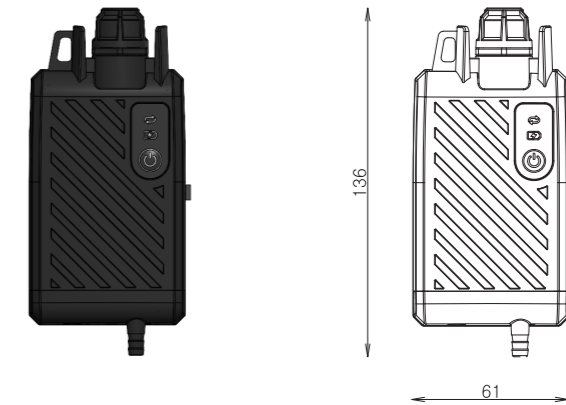

G-Finder Single Type

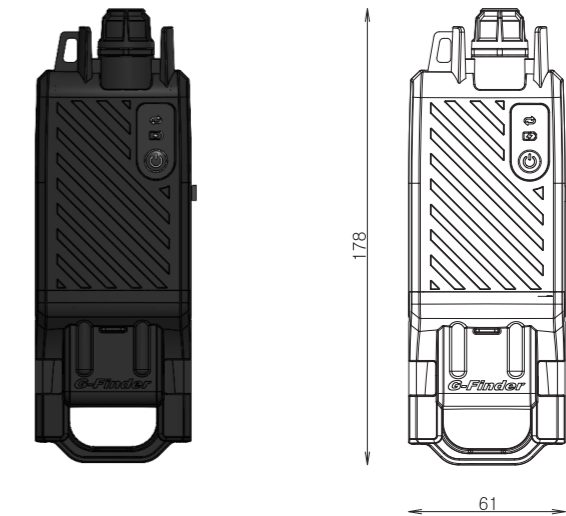

G-Finder Multi Type

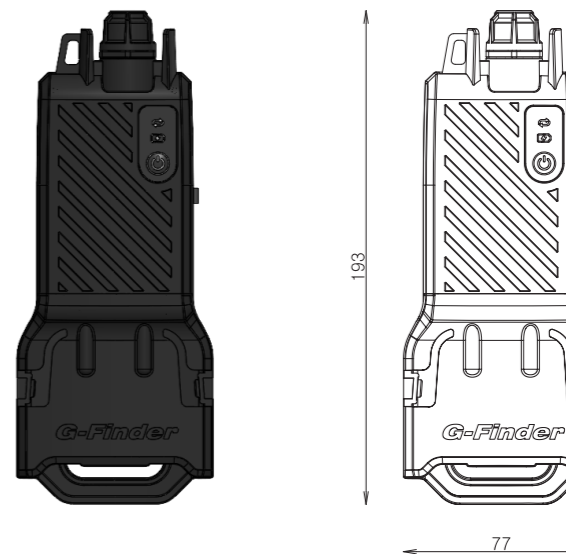

Specifications

Dimensions	61x136x41 mm (GFP-10) 61x211x48 mm (GFP-10-S1) 77x243x48 mm (GFP-10-M4)
Weight	Approx. 208 g (GFP-10) Approx. 349 g (GFP-10-S1) Approx. 483 g (GFP-10-M4)
Operating Temperature Range	Detection : -20°C ~ 50°C Recharge : 0°C ~ 45°C Store : -20°C ~ 25°C
Operating Humidity Range	5 ~ 95 % RH
IP	IP 67
Alarms	Visual, Audible alarm (min. 90dB @10cm)
Flow	0.4 L/min (fix)
Max. Tube Length	15m
Tube Spec.	mm (inch) I.D. x O.D., W.T. 3.18 x 4.76 (1/8" x 3/16"), 0.8 (1/32") 3.18 x 6.35 (1/8" x 1/4"), 1.6 (1/16")
Battery	Rechargeable lithium-ion battery
Charging Voltage	DC 5V (USB Type-C); Um = AC 250V
Charging Time	≤ 7.5 Hours
Run Time	Minimum 20 hours when fully recharged (reflects to the condition of the area such as temperature, storing conditions, etc.)

Certifications

Explosion Proof Certification	KCs	Korea Explosion Proof Certification
	NEPSI	China Explosion Proof Certification
	ATEX	Europe Explosion Proof Certification
	IECEX	International Explosion Proof Certification
Other Certification	KC	Korean Safety Certification
	CE	European Safety Certification

031-490-0800

info@gastron.com

23, Gunpo Advanced Industrial 1-ro, Gunpo-si, Gyeonggi-do

GFP-10

GASTRON DETECTOR

GASTRON