

Portable Gas Leak Detector SP secure

Explication and Features

SP secure is designed to be suitable for leak detection of any gas piping and valves by equipping a built-in sampling pump. Since the measured gas concentration is displayed in digital number, accurate measurement is possible.

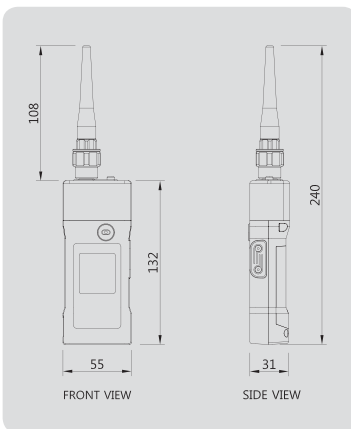

- Sampling pump built in structure
- The digital concentration display
- Detector for the gas leakage
- Both rechargeable battery and alkaline battery are compatible
- Adopt the sensor which detect the low concentrated
- Rechargeable battery is compatible with
- Data logging (Under development)

Applications

Steelworks, Petrochemical plant, Shipbuilding yard, Sewage treatment plant, Mine, Power supply works, Hermetically sealed area (manhole, tank)



Specification

Model	SP Secure		
Measuring gas	LNG/LPG	H2	Xylene
Measuring type	Auto Sampling type		
Measuring method	Catalytic	Electrochemical cell	IR
Measuring range	1~100%LEL	0~1000ppm	0~100%LEL
Sensor life time	> 2 years	> 2 year	> 2 year
Response time	<10sec/90%scale	<75sec/90%scale	<30sec/90%scale
Operation time	About 12 hours		
Accuracy	±3%/Full scale		
Resolution	1%LEL	1ppm	1%LEL
Parameter Control	Right Side switch(calibration, maintenance, alarm setting)		
Operation mode display	Visual : alarm & status icon, Trouble RedLED Audible : buzzer(90dB @ 10cm)		
Measuring value display	LCD Display(3-digit)		
Alarm display	Visual : alarm & status icon Audible : buzzer		
Alarm level set	Programmable within detection range		
Sampling method	Internal sampling pump		
Flow rate	0.5 liter/min		
Program set mode	Alarm value(1,2 alarm) time Set		
Operating temperature	-20℃~50℃		
Operating humidity	10 to 95% RH(Non-condensing)		
Battery power	Rechargeable NI-MH AA Alkaline battery 3ea		
Battery life time	More than 12 hours		
Material	Poly carbonate		
LCD size	32(W) × 40(H) mm		
Dimensions	55(W) × 240(H) × 31(D) mm		
Weight	Standard type : 260g (Battery Including)		
Approval	Ex dia IIB T3(KGS)		