

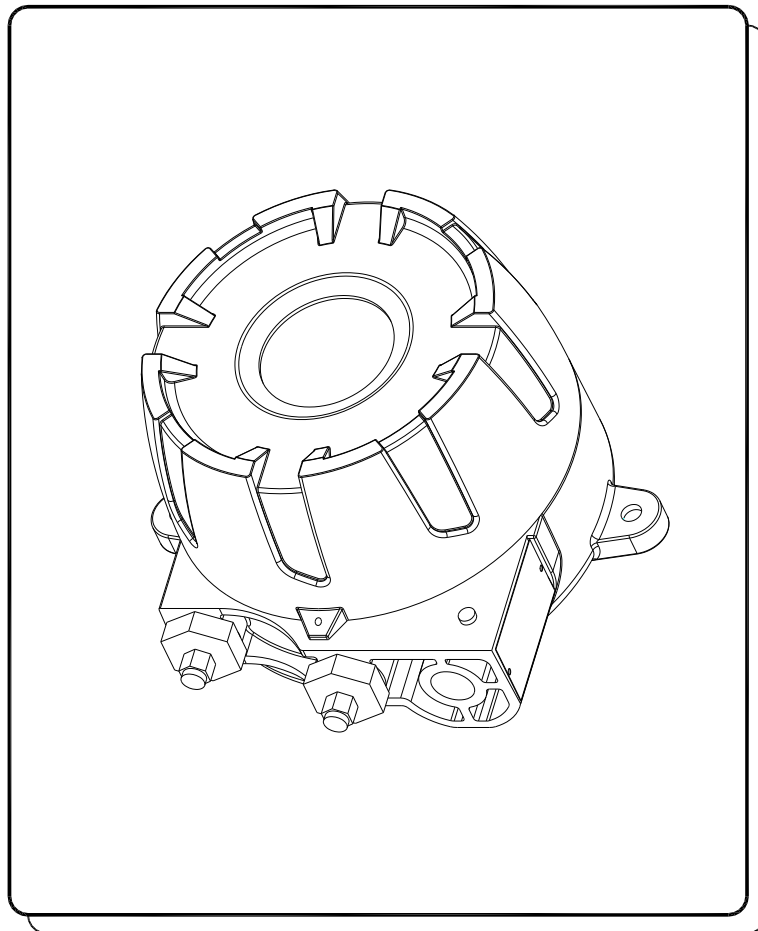

GTD-5000F

Cartridge type

Instruction Manual



For proper use, please read this manual carefully

Thank you for purchasing our GASTRON's product.

Gastron is a specialized company in producing gas detector and gas monitoring system. We have been recognized by customers for our best quality products and excellence in easy-to-use design. We are striving to provide the suitable product that fits customer's needs, and continuously put every effort to develop better gas detector to satisfy customer's requirements. From now on, we will be your reliable partner to shed a bright light on your concern about gas detector. Please contact us if you have any question. You can obtain best solution from us with great satisfaction.

This instruction manual describes how to operate the GTD-5000F gas detector. It also briefly explains how to repair and maintain the device. Please keep this manual in safe place after reading carefully. This instruction manual will be of great help when you encounter any trouble or question while you are using the device.

If you have any problem when using our product, contact us to following address:

- **Address: 18-8, Dogeumdanji 1-gil(Palgok 2-dong), Sangrok-gu, Ansan-si, Gyeonggi-do**
- **Tel : 031-490-0800**
- **Fax : 031-490-0801**
- **URL : www.gastron.com**
- **E-mail : gastron@gastron.com**

Note

- **We recommend that the gas detector should be inspected and calibrated with calibration gas prior to use for accurate operation.**
- **Without getting calibrated, the device might be malfunctioned due to sensor aging problem.**
- **When it is necessary to disassemble the device, technician with special skills for a gas detector must perform it.**
- **For more details about maintenance and calibration of gas detector, contact our technical department via email or visiting our web site.**

TABLE OF CONTENTS

1. Introduction.....	5
2. Structure.....	5
3. Specification	6
4. Components name and description.....	7
4.1. Composing elements	7
4.2. Detailed description of component	8
4.3. Front panel LED display.....	10
5. Menu Table.....	11
6. How to operate.....	14
6.1. Power connection.....	14
6.2. Power On.....	14
6.3. Gas Measuring Mode	15
6.4. Environment Configuration Mode	16
6.5. Program setting.....	18
6.6. Zero Calibration.....	19
6.7. Span Calibration	20
6.8. Alarm data setting - Alarm mode.....	22
6.9. Current time reading and setting	26
6.10. Sensor data checking and setting.....	27
6.10.1. Catridge type sensor.....	27
6.11. Test function setting.....	29
6.12. Flow setting	31
6.13. Maintenance mode configuration	33
6.14. Adjustment mode setting.....	37
7. Error & Warring Message (Troubleshooting).....	39
7.1. Error Code.....	39
7.2. Warning Code	39
8. Communication Interface	40
8.1. 4~20mA Current output conditions.....	40
8.2. 485 MODBUS Interface	40
8.2.1. RS485 Communication configuration.....	40
8.2.2. Address Structure.....	40

8.3. Terminal Block Layout	41
8.4. Details about Terminal Board Ports	42
8.4.1. Power & Output Signal Terminal (CN1)	42
8.4.1. RS485 & Relay Contact Terminal (CN17)	42
9. Terminal Connection Diagram	43
9.1. Power and 4-20mA Signal layout	43
9.1.1. Power and 4~20mA Source layout.....	43
9.1.2. Power and 4~20mA Sink Layout	43
9.2. Alarm signal connection.....	44
9.3. RS-485 Communication Signal Connection.....	44
9.4. How to connect this device to main control of other products.....	45
10. Appearance Drawing and Dimensions	46
10.1. GTD-5000F Appearance Drawing and Dimensions	46
11. Cautions prior to Installation.....	47
11.1. Installation Site Selection (Industrial safety and health regulation).....	47
11.2. Installation Site Selection (High Pressure Gas Safety Control Act)	47
11.3. Cautions on installation.....	48
11.4. Cable Wiring.....	48
12. Ordering Information	49
13. Revision history.....	51

1. Introduction

The GTD-5000F Gas detector has been developed to detect a variety of gases so as to prevent serious accidents caused by unexpected gas leaks in hazardous areas such as industrial plants, gas storage facilities and factories in the process of producing or consuming combustible gases and toxic gases.

The GTD-5000F Gas detector continuously monitors the air for detecting dangerous gas leaks and displays the measured value of gas concentration via FND installed inside of the gas detector. The GTD-5000F also externally provides DC 4-20mA standard output and RS-485 communication signal. In addition, relay contact signal is generated in an occurrence of alarm indicating gas leakage.

For standard output of DC 4-20mA, output receiver can support up to 2,500 meters away from gas detector to get output signal (only if CVVS or CVVSB 1.5sq ↑ Shield Cable is used). RS-485 communication signal can be delivered up to 450 meters (only if RS-485 dedicated line is used).

2. Structure

The body of GTD-5000F is made of steel housing.

The product can be installed in an area where all kinds of toxic and/or combustible gas might be leaked. 4-digit FND is embedded in the gas detector, which shows the gas leaking state to the user on site. The product consists of three parts as follows: (1) display part that presents the measured value of gas concentration, (2) main control part that measures and controls gas concentration and flow rate and (3) terminal part that provides output in several ways such as the current output (DC 4-20mA), RS-485 communication signal or alarm signal.

3. Specification

I T E M S	S P E C I F I C A T I O N
Measuring Type	Auto Sampling type
Measuring Output	FND display(measured value(4-digit), Alarm, Flow rate)
Enclosure	Explosion Proof type
Detectible Gas	Toxic gas, Oxygen, flammable gas
Measuring Method	Electro chemical, catalytic combustion and semiconductor type
Measuring Range	0 – 9,999 Adjustable (see the ordering Information)
Accuracy	≤ ±3% / Full Range
Zero Drift	≤ 2% / Full Range
Operation Temperature	-40 to 60 °C
Operation Humidity	5 to 99% RH (Non-condensing)
Tube	1/4" Teflon Tube
Measuring singal output	4 - 20mA DC / RS-485 Modbus
Alarm Relay contact	SPDT, Load: AC 250V / 1A (Alarm1, Alarm2, Trouble)
Power Supply	Standard : 18 ~31V DC (24V DC normal) / 280mA Max.
	Pyrolyzer(NOTE1) : 18 ~31V DC (24V DC normal) / 520mA Max
Wiring	Standard type : (CVVS or CVVSB 1.5sq ↑)+Shield
Cable Connection Length	4 - 20mA DC Signal : 2500m
	RS-485 Modbus Signal : 1000m
Mounting type	Wall mount
Weight	Standard type : 5kg
Dimensions	Standard type : 226.3(W) × 154(H) × 238(D) mm
Approval	Ex d IIC T6 IP65

[Table 1. Gas detector specification]

※ **NOTE1: Pyrolyzer(PY1000, PY2000) Unit Current consumption**

4. Components name and description

4.1. Composing elements

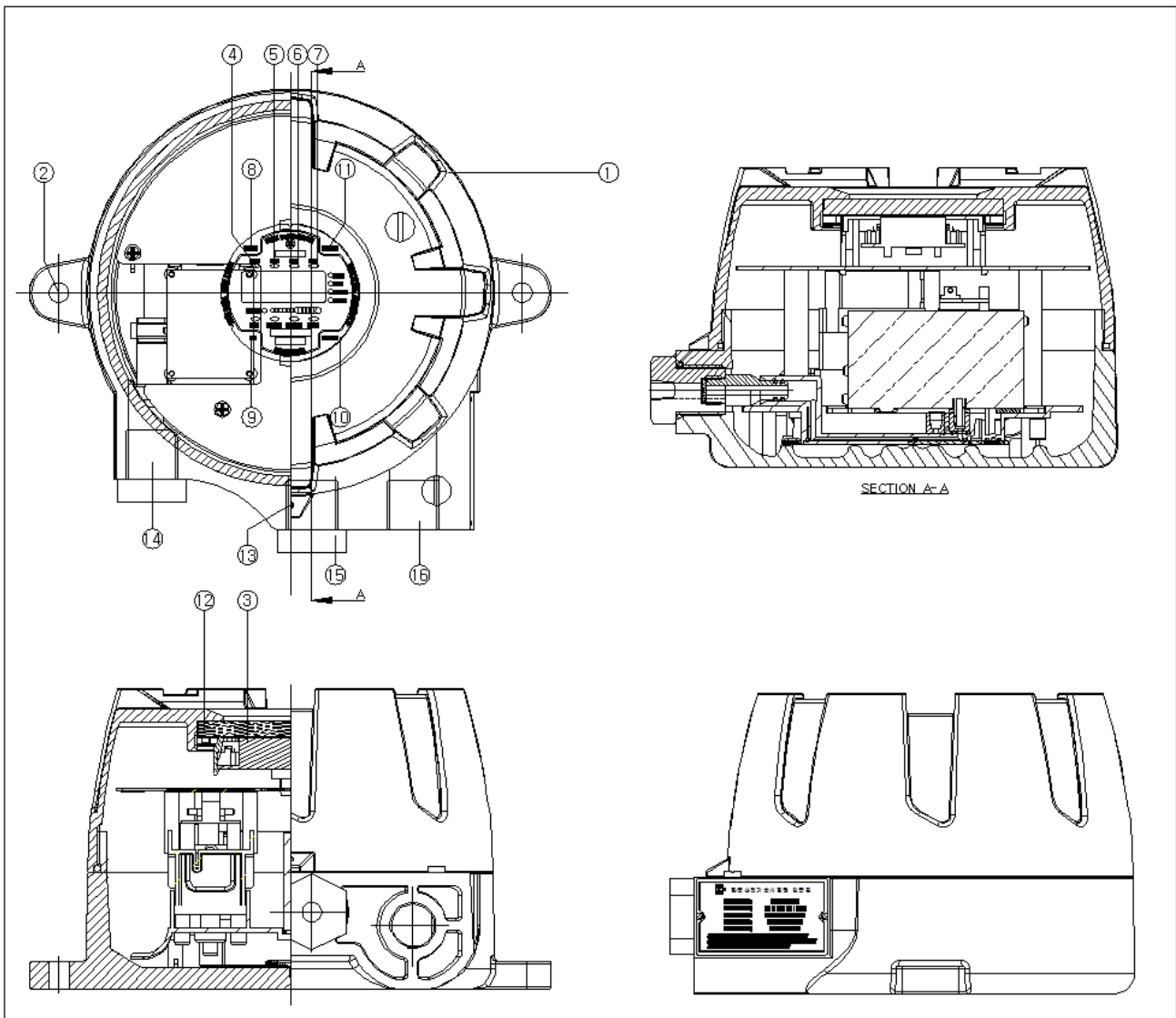

[Figure 1. Components of Gas detector]

No.	Name	No.	Name
1	Case cover	9	Up key
2	Mount Holes	10	Down key
3	LCD display	11	Reset key
4	Power LED (Green)	12	Window Glass(GWIN-95-8-TPG)
5	Trouble LED (Yellow)	13	Cover case fixing screw
6	Alarm1 LED (Red)	14	Gas inlet
7	Alarm2 LED (Red)	15	Gas outlet
8	Function key	16	Gable gland

[Table 2. Gas detector components reference table]

4.2. Detailed description of component

1) **Case cover**

Protects components residing inside of the cover such as PCB board and sensors against external environment changes and/or shock.

2) **Mount Holes**

Mounting hole used for fixing the case firmly.

3) **LCD Display**

Presents the gas concentration measured by the sensors. In setting mode, it displays numbers and icons when the user configures system's parameters. (see *section 4.3 Front LED panel display icon* for details about icon)

4) **Power LED (Green)**

Power LED will turn on when power(DC18~31V) is successfully supplied.

5) **Trouble LED (Yellow)**

Trouble LED will turn on if fault is detected in sensor and/or flow rate. When properly configured, trouble relay contact signal is also output to outside.

6) **Alarm1 LED (Red)**

Alarm1 LED will turn on if the measured gas concentration goes over higher than the Alarm1 setting value. When properly configured, relay contact signal is also output to outside. (Alarm1 value can be set in "alarm setting mode" as the user requires)

7) **Alarm2 LED (Red)**

Alarm2 LED will turn on if the measured gas concentration goes over higher than the Alarm2 setting value. When properly configured, relay contact signal is also output to outside. (Alarm2 value can be set in "alarm setting mode" as the user requires)

8) **Function key**

This function key allows the user to change mode and set value in a function setting mode. When the user presses and holds FUNC key for 2 seconds or more in a measuring mode, the device will enter a menu mode for configuring various functionalities (configuration, program, calibration, alarm and timer etc).

9) **Up key**

This Up key is used to increase a setting value in a function setting mode.

10) **Down key**

This Down key is used to decrease a setting value in a function setting mode. The device will enter a Maintenance Mode (EMS: Emergency Maintenance System) and maint LED will flash if the user presses and holds this key for 2 seconds or more in a measuring mode. If the user presses and holds this key for 2 seconds or more in a maintenance mode, this mode will be released.

11) **Reset key**

The reset key is used when the user needs to go back to menu state or measuring mode from the function setting mode.

12) **Window Glass(GWIN-95-8-TPG)**

This glass enables the user to transparently look the current state of device residing in a housing.

13) **Cover fixing screw**

This screw is used for fixing front cover case to main body case firmly.

14) **Gas inlet**

Sample gas inlet port. (1/4" Tube)

15) **Gas outlet**

Sample gas output port. (1/4" Tube)

16) **Cable gland**

Power and signal cable inlet

4.3. Front panel LED display

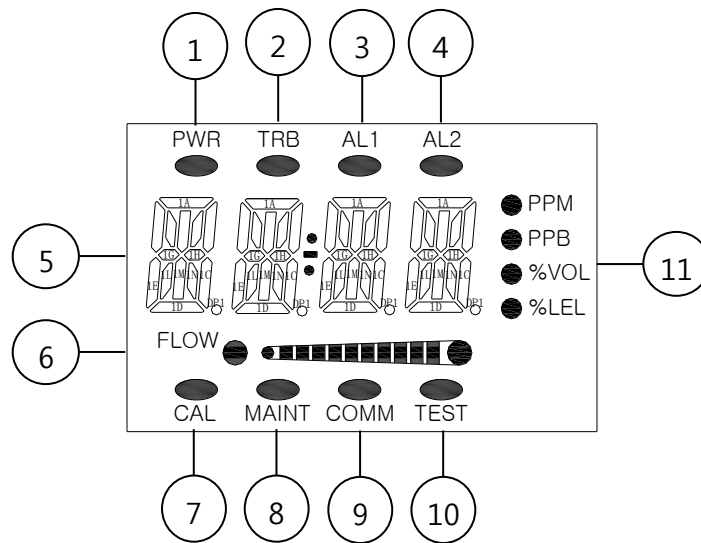

[Figure 2. LED Display Layout]

No	Name	Descriptions
1	Power LED(Green)	This LED turns on if power(DC18~31V) is successfully supplied.
2	Trouble LED	When fault is detected in a process of self-diagnosis, this LED turns on.
3	Alarm1 LED	This Alarm1 LED is indicated when Alarm1 is set or Alarm1 setting value is detected.
4	Alarm2 LED	This Alarm2 LED is indicated when Alarm2 is set or Alarm2 setting value is detected.
5	FND DISPLAY	FND Display is used for indicating the gas concentration value measured by sensor and guiding a setting mode by means of number and icon when configuring parameters.
6	FLOW LED	This LED shows the current flow rate in bar graph.
7	CAL LED	This LED indicates that calibration is in progress.
8	MAINT LED	This LED is shown when engineering mode is in progress.
9	COMM LED	This LED is shown when RS485 communication is in connecting.
10	TEST LED	This LED is shown when Maintenance mode is in progress.
11	Display Unit	Gas measurement unit

[Table 3. LED Display Description]

5. Menu Table

Level1	Level2	Level3	Default
CONF (CONFIGURATION MODE)	485	YES or NO automatically appears depending on whether OPTION BOARD is attached.(YES if attached)	-
	HART		-
	ADD(Address)	OFF, 1~64 (Address for 485 Modbus communication)	OFF
	PSWD(Password)	0~99 (Password setup)	00
	C-TM(Calibration Time)	OFF, 1~12(Gas detector calibration interval: month)	OFF
	SKIP(Skip)	OFF, 1~20(restrained percentage of gas concentration, operable by 20% of full range)	03%
	PYRO(Pyrolyzer)	ON , OFF (setting whether to use of Pyrolyzer consumption current)	OFF
	U-01(Version)	Firmware version number	-
		END	-
PRGM (PROGRAM MODE)	UNIT	PPM, PPB, %VOL, %LEL (Setup measurement unit)	%LEL
	DP-S(Decimal Point)	1000, 100.0, 10.00, 1.000 (Setup decimal point for the measured value)	100
	H-SL(High Scale)	1~9999: Setting measurement full range(High Scale)	100
		END	-
CALB (CALIBRATION MODE)	ZERO	NO , YES	NO
	0	Zero (current measured value)	-
	WAIT(Wait)	-	-
	GOOD(Good)	Good, Fail	-
	0	Measured value after completion of zero calibration	-
	SPAN	NO , YES	NO
	50	Setting standard gas value for span calibration	50%/F.R.
	45	Current measurement value	
	WAIT(Wait)		
	GOOD(Good)	Good if calibration is successful. Otherwise fail	-
	50	Measured value after completion of span calibration	-
	END	-	-
ALAM (ALARM MODE)	LACH(Latching)	ON, OFF	OFF
	EN-Z(Energizer)	ON, OFF	OFF
	AL-1(Alarm 1)	1~90% of full range	20%/F.R.
	1H/1L(Alarm operational direction)	H: Increasing Alarm / L: Decreasing Alarm	1H
	1H00/1L00(Dead band)	0~10%/Full Range	1H00
	AL1T(Alarm1 time)	0~30sec(Alarm delay time)	1
	A1RL(Alarm1 Relay)	ON , OFF(Setting whether using relay or not)	ON
	AL-2(Alarm 2)	1~100% of full range	40%/F.S.
	2H/ 2L(Alarm operational direction)	H: Increasing Alarm / L: Decreasing Alarm	2H
	2H00/2L00(Dead band)	0~10%/Full Range	2H00
	AL2T(Alarm2 time)	0~30sec(Alarm delay time)	1

Level1	Level2	Level3	Default
ALAM (ALARM MODE)	A2RL(Alarm2 Relay)	ON , OFF(Setting whether using relay or not)	ON
	END	-	-
TIME (TIME MODE)	CLOC(Clock)	Current time reading mode	
	2012	Year	
	10-16	Month/Day	
	12:30	Hour/Minute	
	END	-	-
	CLTM(Calibration time)	Calibration date reading mode	
	2012	Year	
	10-16	Month/day	
	12:30	Hour/minute	
	END	-	-
	S-TM(Sensor time)	Sensor manufacturing date reading mode	
	2012	Year	
	10-16	Month/Day	
	12:30	Hour/Minute	
END	-		
S-DT (SENSOR DATA MODE)	TYPE(Sensor Type)	ES(Explosive), TX(Toxic)	TX
	SDIR (Sensor Direction)	PLUS, MINUS	PLUS
	SOUT(Sensor output)	output voltage of sensor(V)	0.000
	SPWR(Sensor power)	Applied voltage of sensor(V)	0.000
	TSET(Sensor time set)	NO, YES(Setting sensor manufacturing date)	NO
	END	-	
TEST (TEST MODE)	FND	FND indicating state verification mode	
	TRLY	Relay ON/OFF when testing	OFF
	T-MA	mA output ON/OFF when testing	OFF
	TGAS	Gas concentration simulation test	
	FOUT	Flow rate sensor reading mode	
	PYRO	Pyrolyzer consumption power reading mode	
	TEMP	Sensor's current temperature reading mode	
	END	-	
FLOW (FLOW MODE)	AUTO(Auto)	Setup flow control method - YES(Auto), no(Manual)	NO
	F-LE(Flow level)	Setup flow level : OFF~1000 ml/min	600ml/min
	F-CT(Flow Control)	ON,OFF(During a specific duration, flow is on or off)	OFF
	F-ON(Flow On)	5~20sec(Pump On time setting)	6sec
	F-OFF(Flow Off)	2~20sec(Pump Off time setting)	12sec
	F-TM(Flow delay time)	15~60sec(Flow error delay time setting)	30sec
	END	-	

Level1	Level2	Level3	Default
M-T (MAINTENANCE MODE)	AOO(mA Output Offset)	-1.00~+1.00, mA Analog Output Offset setting	0
	CSEN(Cross sensitivity)	1.00 ~ 5.00(relative sensitivity value setting)	100
	MUAL (Maintenance Value)	0~Full Range (Setting output value when diagnosing (EMS: Emergency maintenance system))	0
	ZBAN(Zero band)	ON , OFF(Zero band restrained control setting)	OFF
	AUZO(Auto zero)	ON , OFF(Auto zero control setting)	ON
	BAZO(Base Zero)	ON , OFF(Base zero control setting)	ON
	BSPN(Base Span)	ON , OFF(Base span control setting)	ON
	ENGM(Engineering Mode)	ON, OFF(Setting whether to use Engineering Mode)	OFF
	UNDR(Under)	ON , OFF(Setting whether to use Under func)	OFF
	ODT(Output delay time)	OFF, 1~60sec(Measured data delay time setting)	OFF
	ODU(Output delay value)	OFF, 1~20%/F.S(Output signal delay range setting)	OFF
	E-TO (Emergency mode - time out)	ON , OFF (Setting whether to use Time out)	OFF
	FTMA(Fault mA Output)	0mA, 2mA	2mA
	END	-	
ADJ (ADJUST MODE)	FCAL(Flow Calibration)	NO , YES	NO
	0	Pressure sensor value in case of without using pump	-
	500	Value for span calibration	500CC/min
	450	Current measured value	
	MA-C (mA Output Calibration)	mA Output calibration NO, YES	NO
	0A04	4mA output calibration mode	
	0A20	20mA output calibration mode	
	END	-	

[Table 4. Menu Table]

6. How to operate

6.1. Power connection

- 1) Connect jumper pin to an operation power(+24V, GND) of CN16 on terminal PBC and J1.

6.2. Power On

- 1) Verify power connection, voltage and current. Then turn on the power switch on the front of the device.
- 2) Power LED(Green) will light on. Version information(U-01), a sensor type(IR-S : IR type Sensor, CT-S : Cartridge type Sensor), "SELF" message indicating sensor data is being loaded and "R059 ~ R001" will be shown. The device will then proceed to the measuring mode.
- 3) Power-up process takes about 60 seconds. While "R059 ~ R001" are being shown, if RST(reset key) is pressed, the device turns to the measuring mode showing "R04~R01".

	<ul style="list-style-type: none"> ➤ When power switch turns on, PWR LED is ON and the firmware version number is shown like "V-XX" for 1 second in FND (gas reading part) ➤ When the firmware version number is shown like X-XX, This is debug mode. Thus It must be downloaded to standard release version.
	<ul style="list-style-type: none"> ➤ The type of sensor employed in the device is shown. ➤ Two kinds of sensor: IR type Sensor(IR-S) and Cartridge type Sensor(CT-S)
	<ul style="list-style-type: none"> ➤ While the sensor and main controller is being interchanging initial data, "R059 ~ R001" message will show up sequentially for 60 seconds. In this process, if RST key is pressed, the device goes into the measuring mode immediately.
	<ul style="list-style-type: none"> ➤ When completing the sensor warming-up, the device will count from R4 to R1. It will then proceed to the measuring mode. ➤ This R4 to R1 counting message always appear whenever the device turns to the measuring mode from other mode.

6.3. Gas Measuring Mode

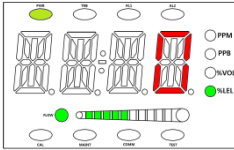
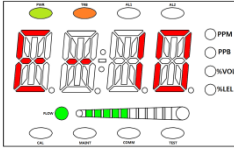
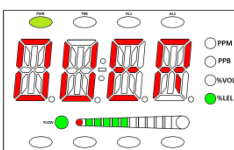
	<ul style="list-style-type: none"> ➤ The gas concentration value sent by sensor is shown in FND digit display part with numbers. The current flow rate is shown by means of bar graph.
	<ul style="list-style-type: none"> ➤ If a fault is detected in the sensor, error message(from "E-10" to "E-33") will flash on and off. At the same time, trouble LED(Orange) will turn on. Regarding error message, see the section, 7. Error & Warring Message (Troubleshooting)
	<ul style="list-style-type: none"> ➤ Gas concentration value sent by the sensor is 10% higher than a high scale setting value, "OVER" message will flash on and off in an interval of 0.5 sec. ➤ If gas concentration value is recognized to be higher than alarm setting value and it lasts during alarm delay time or more, alarm is triggered. ➤ Alarm LED Lamp flashes on and off in 0.5 sec interval while counting alarm delay time. Once the alarm delay time elapses, alarm LED lamp turns on. ➤ Alarm relay turns on, once alarm delay time elapses. ➤ If alarm latch type is "ON", alarm condition and gas concentration will be shown to be as high as possible to measure. In this case, alarm will not be released even after gas concentration goes back to normal. In order to release the alarm, you have to press "Reset" key. ➤ If alarm latch type is "OFF", alarm function will be automatically operated according to the gas concentration.

6.4. Environment Configuration Mode

	<ul style="list-style-type: none"> ➤ In the measuring mode, press and hold "FUNC" key for 2 seconds or more. Then the device requires a password.
	<ul style="list-style-type: none"> ➤ When a password is required, "PSWD"(Password mode) and password input indicator ([- -]) are alternatively shown in an interval of 0.5 second. At the same time, MAINT LED turns on. ➤ Factory setting value is initially [- -] = [00]. The password can be set to the value between [00] and [99]. Once you set the password, press FUNC(function) key. Then you can move to each mode. You can select a mode using UP or DOWN key.
	<ul style="list-style-type: none"> ➤ Select "CONF"(Configuration mode) using UP or DOWN key. Then if you press "FUNC" key, you will enter the environment configuration mode.
	<ul style="list-style-type: none"> ➤ You will see whether RS485 MODBUS BOARD is attached or not. ➤ If attached, the screen will show 485 and YES alternatively. ➤ If not attached, the screen will show 485 and NO alternatively. ➤ If you press "FUNC" key, the device proceeds to the next mode to read whether HART BOARD is attached or not.
	<ul style="list-style-type: none"> ➤ You will see whether HART BOARD is attached or not. ➤ If attached, the screen will show HART and YES. ➤ If not attached, the screen will show HART and NO alternatively. ➤ If you press "FUNC" key, the device proceeds to the next mode to configure ADDRESS.
	<ul style="list-style-type: none"> ➤ Data communication(RS-485) requires unique address for the gas detector. This is an address setting mode, in which you can set the address. ➤ If you press "FUNC" key, the device proceeds to the address setting function.
	<ul style="list-style-type: none"> ➤ If Up or Down key is pressed, the number increases or decreases. The number can be adjustable between 1 and 64. An initial value is set to OFF. ➤ When the desired address(number) is shown, press "FUNC" key. Then address setting is completed. Now the device proceeds to the next step.

	<ul style="list-style-type: none"> ➤ This mode is a password mode(PSWD). ➤ In this mode, you can set the password which allows privileges to modify the data of gas detector. If Up or Down key is pressed, password number will increase or decrease.
	<ul style="list-style-type: none"> ➤ The range of password is from 00 to 99. The password is initially set to be [00]. ➤ When the desired figure is shown, press "FUNC" key. The password is then set to the value and the device goes to the next mode.
	<ul style="list-style-type: none"> ➤ In this mode, sensor calibration interval can be set in a monthly unit. If Up or Down key is pressed, the number increases or decreases.
	<ul style="list-style-type: none"> ➤ Calibration interval is allowed to be set from 01 to 12. This interval is initially set to OFF(not using). ➤ If you press "FUNC" key when the desired number is shown, the interval is set to the displayed number. Then the device turns to next mode.
	<ul style="list-style-type: none"> ➤ This is a skip mode(SKIP) in which you can set a restrained percentage. The restrained percentage is a percentage of gas concentration, which will be displayed '0' rather than its real value. If you press Up or Down key, the percentage number increases or decreases (Initial value: OFF)
	<ul style="list-style-type: none"> ➤ The adjustable range of this value is from 1% to 20%. It is initially set to OFF. ➤ If you press "FUNC" key when the desired number is shown, the restrained percentage is set to the displayed number. Then the device turns to next mode.
	<ul style="list-style-type: none"> ➤ In this mode, you can set whether pyrolyzer is used or not. You can set whether you use pyrolyzer or not, pressing Up or Down key. ➤ For IR type device, this setting is not applicable.
	<ul style="list-style-type: none"> ➤ Select ON if you want to use Pyrolyzer. Otherwise, select OFF. When ON or OFF is displayed, press "FUNC" key. Then the setting is finished, and the device goes to next mode.
	<ul style="list-style-type: none"> ➤ In this mode, program version is displayed. ➤ If you press "FUNC" key, "End" will be shown. While "End" is being shown, if you press "FUNC" key, you enter the menu mode(MENU).
	<ul style="list-style-type: none"> ➤ "END" message indicates that configuration mode is completed. If you press "FUNC" key while "END" is being shown, you enters the menu mode (MENU).

6.5. Program setting

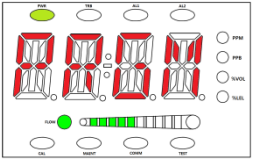
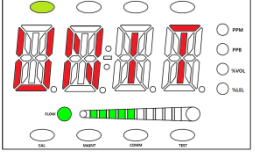
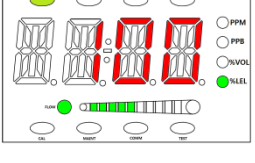
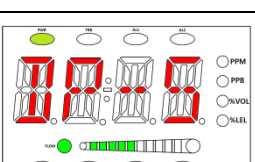
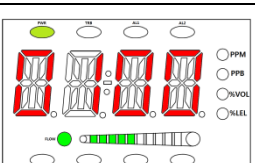
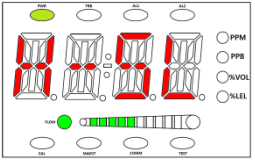
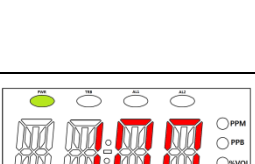
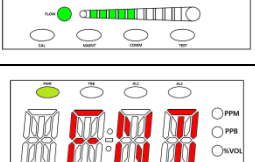
	<ul style="list-style-type: none"> ➤ If you press and hold "FUNC" key for 2 seconds or more in a gas concentration reading state, you will enter the menu selection mode. ➤ Select a program mode (PRGM) using Up or Down key. Then if you press "FUNC" key, you will enter the program setting mode.
	<ul style="list-style-type: none"> ➤ In this mode (UNIT), you can set the gas concentration measurement unit.
	<ul style="list-style-type: none"> ➤ When you press Up or Down key, a unit icon placed on the right side is altered. There are four types of unit supported: PPM, PPB, %VOL and %LEL. The unit is initially set to %LEL. When the desired unit icon flashes on and off, press "FUNC" key. Then the measurement unit is set and the mode proceeds to the next.
	<ul style="list-style-type: none"> ➤ The message "DP-S" denotes a decimal point of gas concentration value. In this mode, you can set the decimal point of gas concentration. ➤ You will enter this mode if you press "FUNC" key while this message is being shown.
	<ul style="list-style-type: none"> ➤ The decimal point is used when necessary to modify it in accordance to the measurement range. You can set the decimal point by pressing Up or Down key. Whenever the Up or Down key is pressed, decimal point is switched in four ways: 0.000, 00.00, 000.0 and 0000. ➤ When the desired point is shown, press "FUNC" key. Then the decimal point is set as you want. When finished setting, you will enter the next.
	<ul style="list-style-type: none"> ➤ The message H-SL denotes "high scale" mode in which you can set the maximum value that can be measured. ➤ While this message H-SL is being shown, press "FUNC" key. Then you will enter high scale setting function. ➤ When a product is released from a factory, the high scale value is set to the value conforming to the local regulation.
	<ul style="list-style-type: none"> ➤ The high scale value can be adjustable according to measurement range. By pressing Up or Down key, the scale value increases or decreases. ➤ While the desired value is shown, press "FUNC" key. Then the high scale value is set to the value. When finished, you will enter the next.
	<ul style="list-style-type: none"> ➤ "END" indicates the program mode is completed. By pressing "FUNC" key, you will enter the menu mode.

6.6. Zero Calibration

	<ul style="list-style-type: none"> ➤ If you press and hold "FUNC" key for 2 seconds or more in the measuring mode, you will enter the menu selection mode. ➤ Select "CALB"(Calibration mode) by pressing Up or Down key. ➤ If "FUNC" key is pressed while "CALB" is being shown, CAL LED at the left bottom of the screen turns on. Then you will enter Clibration mode.
	<ul style="list-style-type: none"> ➤ In this screen, you can select Zero Calibration mode. While "ZERO" is being displayed, press "FUNC" key. Then you will enter Zero calibration mode.
	<ul style="list-style-type: none"> ➤ If you press "FUNC" key after selecting "YES" using Up or Down key, you will read a gas concentration value which is currently measured.
	<ul style="list-style-type: none"> ➤ Insert clean air for one minute at the rate of 600mL/min into a sensor with calibration tool. ➤ Once the measured value has been stabilized, press "FUNC" key. Then zero calibration will be performed automatically with "WAIT" message being presented.
	<ul style="list-style-type: none"> ➤ When the calibration is successfully completed, GOOD message will be shown for 2 seconds. Then the device turns to calibration concentration reading mode. ➤ If the calibration fails, "FAIL" message will be shown for 2 seconds. Then the device switches to calibration concentration reading mode.
	<ul style="list-style-type: none"> ➤ In calibration concentration display mode, press "FUNC" key. Then the device turns to a span calibration mode straight away. If "RST" key is pressed, it moves to the calibration mode(CALB).

6.7. Span Calibration

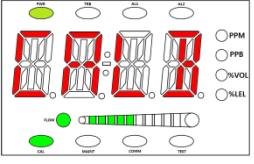
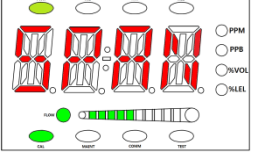
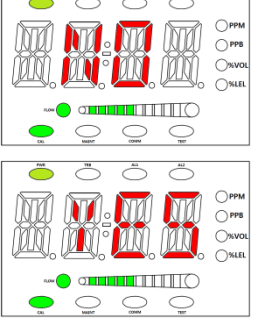
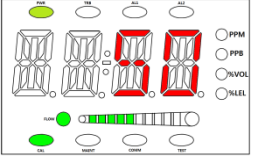
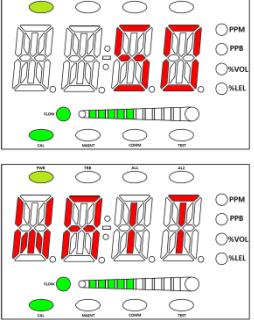
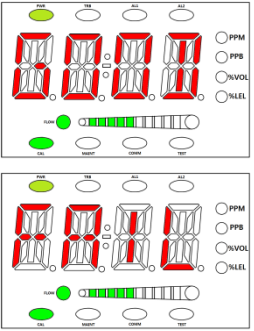
	<ul style="list-style-type: none"> ➤ If you press and hold "FUNC" key for 2 seconds or more in the measuring mode, you will enter the menu selection mode. ➤ To enter the calibration mode, select "CLAB" using Up or Down key. While the "CALB" is being displayed in the screen, press "FUNC" key. Then CAL LED at the left bottom turns on and you enter the calibration mode
	<ul style="list-style-type: none"> ➤ Select "SPAN" using Up or Down key, which indicates span calibration mode. While "SPAN" is being shown, press "FUNC" key. Then you will enter the span calibration mode.
	<ul style="list-style-type: none"> ➤ In this screen, you can choose whether to perform the span calibration or not. ➤ In order to start the span calibration process, select "YES" using Up or Down key. Then press "FUNC" key. Span calibration will start.
	<ul style="list-style-type: none"> ➤ This mode allows you to set a standard gas value. In this mode, concentration value will flash. Select the number using Up or Down key. While the desired number is being shown, if you press "FUNC" key. Then the standard gas value is set to the value.
	<ul style="list-style-type: none"> ➤ Insert standard gas for one minute at the rate of 300mL/min into a sensor with calibration tool. ➤ Once the measured value has been stabilized, press "FUNC" key. Then span calibration will be performed automatically with "WAIT" message indicated.
	<ul style="list-style-type: none"> ➤ When the calibration is successfully completed, GOOD message will be shown for 2 seconds. Then the device turns to calibration concentration reading mode. ➤ If the calibration fails, "FAIL" message will be shown for 2 seconds. Then the device switches to calibration concentration reading mode.

	<p>➤ If you press "FUNC" key in a calibration concentration reading mode, "END" message will appear. While "END" is being shown, press "FUNC" key again. Then the device will switch to "CALB" mode.</p>
	<p>➤ "END" indicates that calibration setting has been completed. While "END" is being shown, press "FUNC" key. Then you will enter the menu mode.</p>

6.8. Alarm data setting - Alarm mode

	<ul style="list-style-type: none"> ➤ If you press and hold "FUNC" key for 2 seconds or more in the gas reading state, you will enter the menu selection mode. ➤ To enter the alarm setting mode, select "ALAM" (alarm mode) using Up or Down key. While the "ALAM" is being displayed, press "FUNC" key. Then you will enter alarm setting mode.
	<ul style="list-style-type: none"> ➤ This mode(Latch) allows you to set alarm latch type. While "LACH" is being shown, press "FUNC" key. Then you will enter the latch setting mode.
	<ul style="list-style-type: none"> ➤ Whenever Up or Down key is pressed, "ON" and "OFF" will appear alternatively. ➤ While the desired type is being shown, press "FUNC" key. Then alarm latch type is set to the shown value. The device will switch to the next mode. ➤ There are two options for alarm latch type: "ON" and "OFF". If OFF, alarm will be reset automatically. If ON, alarm will be released only if the user presses Rset key explicitly.
	<ul style="list-style-type: none"> ➤ This mode allows you to set the energizer function of trouble/alarm relay. If you press "FUNC" key, you will enter alarm relay energizer setting mode.
	<ul style="list-style-type: none"> ➤ When Up or Down key is pressed, "ON" and "OFF" will appear alternatively. ➤ While the desired value is being shown, press "FUNC" key. Then the energizer mode is set to as desired. The device will then switch to the next mode. ➤ There are two options for energizer mode: "ON" and "OFF". If option is set to OFF, relay will be automatically connected to a contact in occurrence of trouble/alarm. If option is ON, the contact will be disconnected(OFF) if alarm occurs when the contact is being connected.
	<ul style="list-style-type: none"> ➤ A message "AL-1" is shown in the screen, which indicates that this mode allows you to set Alarm1 function.
	<ul style="list-style-type: none"> ➤ In this mode, you can set the value for Alarm1 Level. Alarm1 Level can be adjustable in a range of 1 to 90% of high scale value. ➤ Whenever Up or Down key is pressed, the value increases or decreases. ➤ While the desired value is being shown, press "FUNC" key. Then alarm1 is set to the shown value. The device will then proceed to the next mode. ➤ When a product is released from a factory, the alarm1 level is set to the

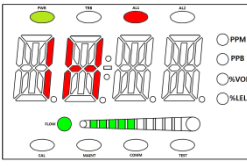
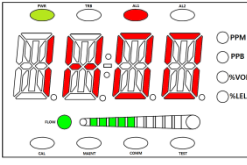
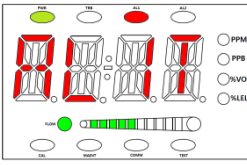
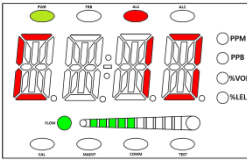
	<p>value conforming to the local regulation.</p> <ul style="list-style-type: none"> ➤ This mode allows you to set the operational direction of Alarm1. When Up or Down key is pressed, "1H" and "1L" appears alternatively. ➤ "1H" indicates an alarm will operate when the measured value equals to Alarm1 value or higher. "1L" indicates an alarm will operate when the measured value equals to Alarm1 value or lower. ➤ Select "FUNC" key while the desired mode is being shown. The value is set to the shown value and then the device goes to the next mode.
	<ul style="list-style-type: none"> ➤ This mode allows you to set the dead band in which alarm1 will be operable. Value can be set by using Up or Down key. ➤ If Alarm1 is set to "1H" mode, alarm1 will operate when the measured gas value reaches alarm setting value plus dead band value or more. Alarm1 will be released when the measured value goes down to alarm setting value minus dead band value or less. ➤ If Alarm1 is set to "1L" mode, alarm1 will operate when the measured gas value goes down to alarm setting value minus dead band value or less. Alarm1 will be released when the measured value goes up to alarm setting value plus dead band value or higher. ➤ While the desired alarm1 dead band value is being shown, press "FUNC" key. Then value setting is finished. The device will then proceed to the next mode. ➤ This function allows the user to set hysteresis value. Its purpose is to avoid the symptom in which alarm1 is turned on and off repeatedly when gas concentraton value remains around alarm1 setting value. When the product is released from manufacturing factory, this value is set to 0. ➤ For example) alarm is turned on 22% LEL and off 18% LEL in case of 20% LEL of alarm setting and 2% LEL of dead band.
	<ul style="list-style-type: none"> ➤ A message "AL1T" indicates that this mode is alarm1 delay time setting function.
	<ul style="list-style-type: none"> ➤ Delay time can be set from 0 to 60 seconds. The purpose of the time delay is to avoid an occurrence of instant faulty operation caused by shock or noise from outside. ➤ Alarm1 delay time can be set using Up or Down key. Whenever Up or Down key is pressed, the time increases or decreases by one second unit. ➤ Press "FUNC" key when the desired value is being shown. Then alarm1 delay time is set as desired, and the setting will proceed to the next. ➤ For example) Alarm is turned on after five seconds are elapsed maintaining higher than alarm setting value in case of 20% LEL of alarm setting and 5 seconds of delay time. The alarm is not turned on straight away, if the

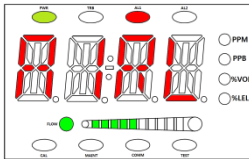
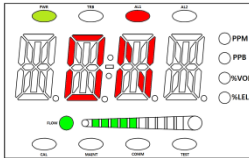
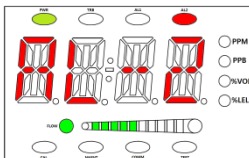
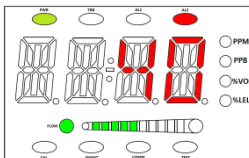
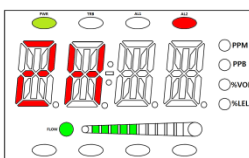
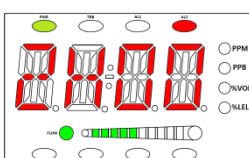
	<p>alarming condition is not maintained during 5 seconds.</p>
	<ul style="list-style-type: none"> ➤ A message "A1RL" is shown in the screen, which indicates that this mode allows you to set Alarm1(Relay) contact point output. ➤ This is a mode in which you can set alarm1 contact point output. "ON" and "OFF" will be shown alternatively when Up or Down key is pressed. ➤ Press "FUNC" key whe the desired method is being shown. Then alarm1 contact point output mode is set as desired. The setting will then proceed to the next. ➤ There are two options for alarm1 contact output mode. If OFF, alarm1 contact output will not be generated. If ON, it will be generated.
	<ul style="list-style-type: none"> ➤ A message "AL-2" is shown in the screen, which indicates that this mode allows you to set Alarm2 function.
	<ul style="list-style-type: none"> ➤ In this mode, you can set the value for Alarm 2 level. Available value is from 1 to 100% of high scale value. ➤ Whenever Up or Down key is pressed, the value increases or decreases. ➤ While the desired value is being shown, press "FUNC" key. Then alarm2 is set to the shown value. The device will then proceed to the next mode. ➤ When a product is released from a factory, the alarm2 level is set to the value conforming to the local regulation.
	<ul style="list-style-type: none"> ➤ This mode allows you to set the operational direction of Alarm2. When Up or Down key is pressed, "2H" and "2L" appears alternatively. ➤ "2H" indicates an alarm will operate when the measured value equals to Alarm2 value or higher. "2L" indicates an alarm will operate when the measured value equals to Alarm2 or lower. ➤ Press "FUNC" key while the desired mode is being shown. The value is set to the shown value and then the device goes to the next mode.
	<ul style="list-style-type: none"> ➤ This mode allows you to set the dead band in which alarm2 will be operable. Value can be set by using Up or Down key. ➤ If Alarm2 is set to "2H" mode, alarm2 will operate when the measured gas value reaches alarm setting value plus dead band value or higher. Alarm2 will be released when the measured value goes down to alarm setting value minus dead band value or less. ➤ If Alarm2 is set to "2L" mode, alarm2 will operate when the measured gas value goes down to alarm setting value minus dead band value or less. Alarm2 will be released when the measured value goes up to alarm setting value plus dead band value or higher. ➤ While the desired alarm2 dead band value is being shown, press "FUNC"

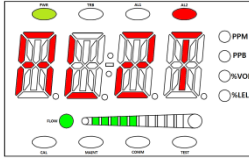
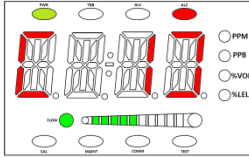
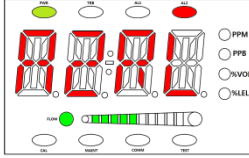
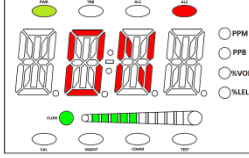
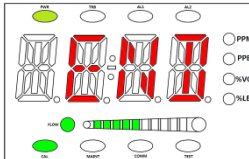
	<p>key. Then value setting is finished. The device will then proceed to the next mode.</p> <ul style="list-style-type: none"> ➤ This function allows the user to set hysteresis value. Its purpose is to avoid the symptom in which alarm1 is turned on and off repeatedly when gas concentration value remains around alarm2 setting value. When the product is released from manufacturing factory, this value is set to 0. ➤ For example) alarm is turned on 22% LEL and off 18% LEL in case of 20% LEL of alarm setting and 2% LEL of dead band.
	<ul style="list-style-type: none"> ➤ A message "AL2T" indicates that this mode is alarm2 delay time setting function.
	<ul style="list-style-type: none"> ➤ Delay time can be set from 0 to 60 seconds. The purpose of the time delay is to avoid an occurrence of instant faulty operation caused by shock or noise from outside. ➤ Alarm2 delay time can be set using Up or Down key. Whenever Up or Down key is pressed, the time increases or decreases by one second unit. ➤ Press "FUNC" key when the desired value is being shown. Then alarm2 delay time is set as desired, and the setting will proceed to the next. ➤ For example) Alarm is turned on after five seconds are elapsed maintaining higher value than alarm setting value in case of 20% LEL of alarm setting and 5 seconds of delay time. The alarm is not turned on straight away, if the alarming condition is not maintained during 5 seconds.
	<ul style="list-style-type: none"> ➤ A message "A2RL" is shown in the screen, which indicates that this mode allows you to set Alarm2(Relay) contact point output.
	<ul style="list-style-type: none"> ➤ This is a mode in which you can set alarm2 contact point output. "ON" and "OFF" will be shown alternatively when Up or Down key is pressed. ➤ Press "FUNC" key when the desired method is being shown. Then alarm2 contact point output mode is set as desired. The setting will then proceed to the next. ➤ There are two options for alarm2 contact output mode. If OFF, alarm2 contact output will not be generated. If ON, it will be generated.
	<ul style="list-style-type: none"> ➤ A message "END" indicates that alarm mode setting is completed. While "END" is being shown, press "FUNC" key. Then you will enter the menu mode.

6.9. Current time reading and setting

	<ul style="list-style-type: none"> ➤ If you press and hold "FUNC" key for 2 seconds or more in the gas reading state, you will enter the menu selection mode. ➤ Select "TIME" using Up or Down key. While "TIME" is being shown, press "FUNC" key. Then you will enter the time menu mode.
	<ul style="list-style-type: none"> ➤ Select "CLOC" using Up or Down key. While "CLOC" is being displayed, press "FUNC" key. Then you will enter the current time reading and setting mode. ➤ Current time is checked by three item: year/date/time. If you press and hold both of Up and Down key at the same time while time(hour & min) shown, you will enter the time setting mode. In the time setting mode, a corresponding item of year/date/time will blink. When it blinks, you can set it in a sequential order.
<div style="display: flex; justify-content: space-around; align-items: center;"> <div style="text-align: center;"> <p>(Year setting)</p> </div> <div style="text-align: center;"> <p>(Date setting)</p> </div> <div style="text-align: center;"> <p>(Time setting)</p> </div> </div>	
	<ul style="list-style-type: none"> ➤ This mode allows you to read the sensor manufacturing date. Sensor manufacturing date can be registered in a S-DT(Sensor Data) mode.
<div style="display: flex; justify-content: space-around; align-items: center;"> <div style="text-align: center;"> <p>(Year setting)</p> </div> <div style="text-align: center;"> <p>(Date setting)</p> </div> <div style="text-align: center;"> <p>(Time setting)</p> </div> </div>	
	<ul style="list-style-type: none"> ➤ This mode allows you to read the latest time when span calibration has been done. This time data is automatically registered when "SPAN" calibration is performed in a "CALB" mode.
<div style="display: flex; justify-content: space-around; align-items: center;"> <div style="text-align: center;"> <p>(Year setting)</p> </div> <div style="text-align: center;"> <p>(Date setting)</p> </div> <div style="text-align: center;"> <p>(Time setting)</p> </div> </div>	
	<ul style="list-style-type: none"> ➤ A message "END" indicates that time mode setting is completed. While "END" is being shown, press "FUNC" key. Then you will enter the menu mode.

6.10. Sensor data checking and setting

6.10.1. Cartridge type sensor

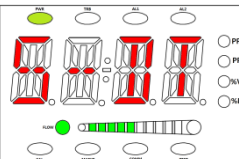
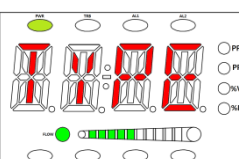
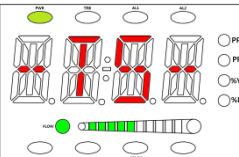
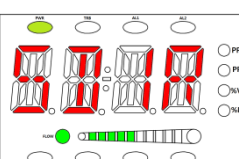
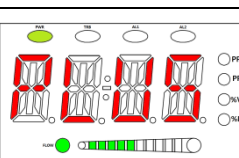
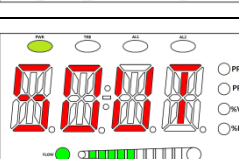
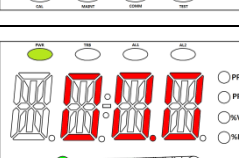
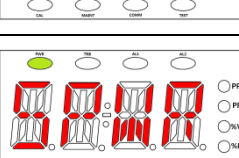
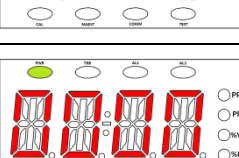
	<ul style="list-style-type: none"> ➤ If you press and hold "FUNC" key for 2 seconds or more in the gas reading state, you will enter the menu selection mode. ➤ To enter the sensor data checking & setting mode, select "S-DT" using Up or Down key. While the "S-DT" is being displayed in the screen, press "FUNC" key. Then you will enter the sensor data checking & setting mode.
	<ul style="list-style-type: none"> ➤ In the sensor type mode("TYPE"), the device will present the sensor type of the sensor cartridge. ➤ There are two types supported: "ES" for flammable and "TS" for toxic sensor.
	<ul style="list-style-type: none"> ➤ Once the cartridge sensor is attached, the type will be set automatically. The type is not allowed to be modified by the user.
	<ul style="list-style-type: none"> ➤ In the sensor direction mode("SDIR"), the device will present a polarity of sensor output voltage for the sensor cartridge.
	<ul style="list-style-type: none"> ➤ There are two directions: "PLUS" and "MIUS"(minus). "PLUS" indicates the sensor generates the output in (+) direction, while "MIUS"(minus) in (-) direction according to the gas concentration. To set the value, use Up or Down key.
	<ul style="list-style-type: none"> ➤ The sensor output mode("SOUT") allows you to read the sensor output voltage(mV) sent by sensor cartridge.
	<ul style="list-style-type: none"> ➤ Sensor output voltage is being presented.
	<ul style="list-style-type: none"> ➤ The sensor power mode("SPWR") allows you to read a bias voltage of sensor cartridge. (unit: V)
	<ul style="list-style-type: none"> ➤ Bias voltage of the sensor is being presented.

	<p>➤ The time set mode("TSET") allows you to set the sensor manufacturing date.</p>
	<p>➤ If "YES" is selected, the sensor manufacturing date is set to the current time. If "NO" is selected, the sensor manufacturing date is not changed.</p>
	<p>➤ A message "END" indicates that sensor data mode setting is completed. While "END" is being shown, press "FUNC" key. Then you will enter the menu mode.</p>

6.11. Test function setting

	<ul style="list-style-type: none"> ➤ If you press and hold "FUNC" key for 2 seconds or more in the gas reading state, you will enter the menu selection mode. ➤ To enter the test function setting mode, select "TEST" using Up or Down key. While the "TEST" is being displayed in the screen, press "FUNC" key. Then you will enter the test mode.
	<ul style="list-style-type: none"> ➤ This mode allows you to check and verify FND and all icons. When you press "FUNC" key, you will enter FND test mode.
	<ul style="list-style-type: none"> ➤ In this mode, FND and all icons are turned on. You can check the states how FND and all icons are displayed.
	<ul style="list-style-type: none"> ➤ The test relay mode("TRLY") allows you to set whether using the alarm relay or not while gas concentration simulation is in progress.
	<ul style="list-style-type: none"> ➤ If you select "OFF", relay will not be operated. If you select "ON", relay will be operated.
	<ul style="list-style-type: none"> ➤ The test mA output mode("T-MA") allows you to set on or off 4-20mA current while gas concentration simulation is in progress.
	<ul style="list-style-type: none"> ➤ If you select "OFF", the current output will be fixed to be 4mA without changing according to the concentration value. If you select "ON", it will be changed according to the concentration value.
	<ul style="list-style-type: none"> ➤ The test gas mode(Test gas) allows you to conduct gas concentration simulation test without cooperating with the sensor. Using Up or Down key, you can adjust the gas concentration value which is blinking. When the value is adjusted, the device will work properly in terms of alarm and output current, according to the changed value.
	<ul style="list-style-type: none"> ➤ You can adjust the gas concentration value as you wish using Up or Down key.

	<p>➤ In the flow output mode("FOUT"), measured flow rate, pump voltage (unit: V) and output voltage (unit: mV) sent by flow rate sensor will be presented by digital number.</p>
	<p>➤ This is a screen to show the measured flow rate. Using Up or Down key, you can read pump voltage level (unit: V). Pump voltage value can be adjusted using Up or Down key.</p>
	<p>➤ In this screen, output voltage(mV) sent by a flow sensor is presented. Using Up or Down key, you can read pump voltage level(unit: V). The voltage value can be adjusted using Up or Down key.</p>
	<p>➤ This is a mode presenting the power consumed by pyrolyzer.</p>
	<p>➤ If you set "OFF"(no-use) for "PYRO"(pyrolyzer) in "CONF" mode, consumed power is presented by "OFF".</p>
	<p>➤ This mode("TEMP") is a mode presenting a temperature of gas detector.</p>
	<p>➤ The temperature of inside of the gas detector is indicated.</p>
	<p>➤ A message "END" indicates that test function setting is completed. While "END" is being shown, press "FUNC" key. Then you will enter the menu mode.</p>

6.12. Flow setting

	<ul style="list-style-type: none"> ➤ If you press and hold "FUNC" key for 2 seconds or more in the gas reading state, you will enter the menu selection mode. ➤ To enter the flow setting mode, select "FLOW" using Up or Down key. While the "FLOW" is being displayed in the screen, press "FUNC" key. Then you will enter the flow setting mode.
	<ul style="list-style-type: none"> ➤ This mode("AUTO") allows you to set the way to control auto flow control method. While "AUTO" is being displayed, press "FUNC" key. Then you will enter the mode to select "YES" or "NO".
	<ul style="list-style-type: none"> ➤ You can select YES or NO using Up or Down key. ➤ If you select "YES", flow will be controlled in accordance to the flow setting value. If you select "NO", flow control will be done by manual. ➤ Default setting is "YES".
	<ul style="list-style-type: none"> ➤ This mode("F-LE") allows you to set a flow level.
	<ul style="list-style-type: none"> ➤ Flow rate can be set using Up or Down key. "OFF" means a state that pump is off. ➤ You can set the value from 50 to 1000 mL/min, ➤ By default, it is set to 500ml/min.
	<ul style="list-style-type: none"> ➤ This mode("F-CT") allows you to set a flow ON/OFF function.
	<ul style="list-style-type: none"> ➤ If "F-CT" function is set to "ON", Pump ON/OFF function is carried out. ➤ If "F-CT" function is set to "OFF" Pump ON/OFF function is not carried out. ➤ The initial set is to be "OFF"

	<ul style="list-style-type: none"> ➤ This mode("F-ON") allows you to set a pump ON time. It will be displayed when the "F-CT" function is set to ON. ➤
	<ul style="list-style-type: none"> ➤ Time can be set using Up or Down key. Available range is from 5 to 20 seconds. By default, this value is set to 6 seconds.
	<ul style="list-style-type: none"> ➤ This mode("F-OFF") allows you to set a pump OFF time. It will be displayed when the "F-CT" function is set to ON.
	<ul style="list-style-type: none"> ➤ Time can be set using Up or Down key. Available range is from 2 to 20 seconds. By default, this value is set to 12 seconds.
	<ul style="list-style-type: none"> ➤ The flow time mode("F-TM") allows you to set the time when error and warning message is generated in case that flow rate gets lower than 50ml/min (E-21) or higher than 1000ml/min(E-22).
	<ul style="list-style-type: none"> ➤ Time can be set using Up or Down key. Available range is from 15 to 60 seconds. By default, this value is set to 30 seconds.
	<ul style="list-style-type: none"> ➤ A message "END" indicates that flow rate setting is completed. While "END" is being shown, press "FUNC" key. Then you will enter the menu mode.

6.13. Maintenance mode configuration

※  **The operation described in this section must not be allowed by general users.**

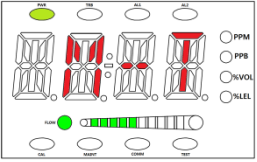
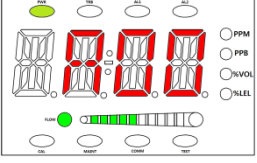
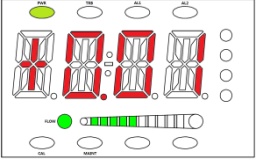
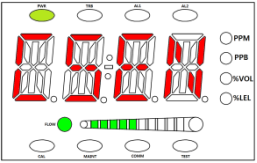
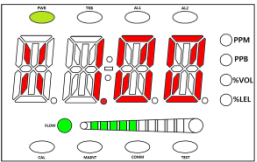
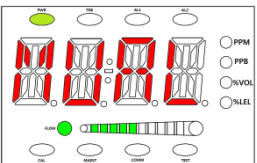
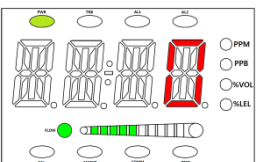
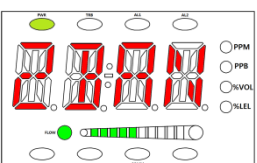
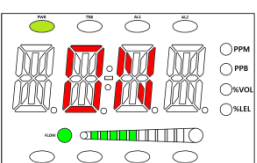
	<ul style="list-style-type: none"> ➤ If you press and hold "FUNC" key for 2 seconds or more in the gas reading state, you will enter the menu selection mode. ➤ To enter the maintenance mode, select "M-T"(Maintenance mode) using Up or Down key first. While the "M-T" is being displayed in the screen, press "FUNC" key. Then you will enter the maintenance mode.
	<ul style="list-style-type: none"> ➤ The analog output offset mode("AOO") allows you to remove uniform output offset caused by installation line and other environmental reasons.
	<ul style="list-style-type: none"> ➤ You can adjust the offset rate using Up or Down key. The available range is -1.00~+1.00. By default, it is set to 0.
	<ul style="list-style-type: none"> ➤ The cross sensitivity mode("CSEN") allows you to set a relative sensitivity of the sensor. ➤ For example, if you use the device calibrated referring methane gas(CH₄) for measuring isobutene, you need to utilize the relative sensitivity factor.
	<ul style="list-style-type: none"> ➤ The sensitivity rate can be adjusted in a range of 1.00 ~ 5.00 using Up or Down key. By default, the value is set to 1.00.
	<ul style="list-style-type: none"> ➤ The maintenance value level mode("MUAL") allows you to set the output value generated while the emergency maintenance system(EMS) is in progress.
	<ul style="list-style-type: none"> ➤ The value can be adjusted in a range of 0 – full range using Up or Down key. ➤ By default, the value is set to 0. For oxygen, default value is set to 20.9.
	<ul style="list-style-type: none"> ➤ The zero band auto numeric mode("ZBAN") is a mode in which the measured value is post-processed in a range of 2%-6.6%.
	<ul style="list-style-type: none"> ➤ If "ZBAN" function is set to "ON", post-processing is carried out in these ways: (1) if the measured value is less than 2%, then subtract 0%, (2) less than 3.3%, then subtract 2% from the measured value, and (3) less than 6.6%, then subtract 1.6%.

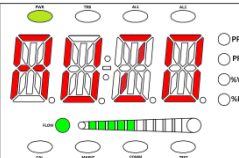
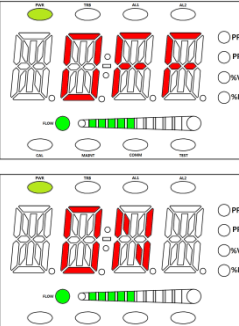
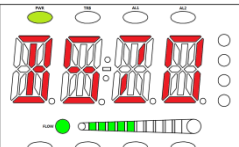
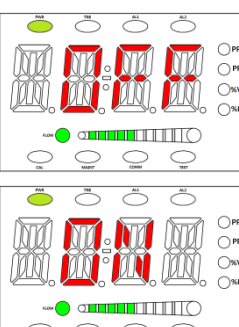
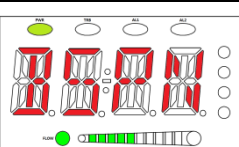
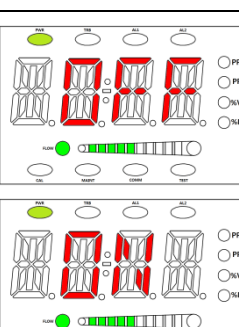
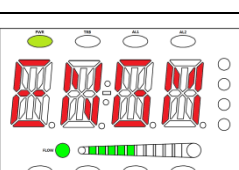
	<p>➤ The auto zero mode("AUZO") is a mode to carry out zero calibration automatically.</p>
	<p>➤ In case of "ON", a zero calibration is executed automatically in this manner: if a measured value remains by varying within $\pm 0.5\%$ for 10 minutes or more, the value at that moment is used as zero point.</p>
	<p>➤ The base zero mode("BSZO") is a mode to execute a zero calibration automatically.</p>
	<p>➤ In case of "ON", zero calibration is carried out automatically in this manner: if a measured value remains by varying within $\pm 0.2\% - \pm 1.5\%$ for 5 seconds or more, the value at that moment is used as zero point.</p>
	<p>➤ The base span mode("BSPN") is a mode to execute a span calibration automatically.</p>
	<p>➤ In case of "ON", span calibration is executed automatically in this manner: if a measured value remains by varying within $\pm 0.15\% \sim \pm 1.5\%$ of span setting value for 5 seconds or more, the value at that moment is used as zero point.</p>
	<p>➤ The engineering mode("ENGM") allows you to select whether unprocessed data would be viewed or not. This mode can be used temporarily in a process of device diagnosis.</p>

	<ul style="list-style-type: none"> ➤ If it is set to "ON", data will be displayed without being processed. (the value under "0" is displayed, the measured value is displayed without indicating under or over) ➤ Default setting is OFF. In case of "OFF", the value under "0" will be displayed as "0" ➤ While you stay in the engineering mode, MAIN LED will blink in an interval of 0.5 second.
	<ul style="list-style-type: none"> ➤ This mode is a under mode ("UNDR"), in which you can select whether indicating "UNDR" or not, in case that the gas detector output goes below 10% of "0" point.
	<ul style="list-style-type: none"> ➤ If it is set to "ON", "UNDR" will be indicated when the gas detector output goes below 10% of "0" point. ➤ If "OFF", the value under "0" will be shown as "0" without indicating "UNDR". ➤ Default setting is OFF.
	<ul style="list-style-type: none"> ➤ The output delay time mode("ODT") allows you to configure an output delay time (unit: second). The measured value will appear on the screen after the delay time is elapsed. Time can be set as OFF or between 1 and 60 seconds. (Default setting: OFF)
	<ul style="list-style-type: none"> ➤ The user can select the delay time in a range of 0-60 seconds. After the setting time is elapsed, the measured value will be shown. ➤ If it is set to OFF, the measured value will be shown immediately after being measured without delay.
	<ul style="list-style-type: none"> ➤ The output delay value mode("ODV") allows you to configure the range of the measured value which you want to delay. (Default setting: OFF)
	<ul style="list-style-type: none"> ➤ The value can be set up to 20% of full range. If the measured value falls into the specified range, it will not be displayed until the delay is elapsed. ➤ If it is set to OFF, the measured value will be shown immediately after being measured without delay.

	<p>➤ The emergency mode time out mode("E-TO") allows you to configure whether emergency mode is automatically dismissed. (Default setting: OFF)</p>
	<p>➤ If it is set to ON, an emergency mode will be automatically dismissed after 30 minutes later.</p> <p>➤ By default, it is set to OFF.</p>
	<p>➤ The fault mA mode("FTMA") allows you to configure the output current generated in an occurrence of fault. You can set this to 0mA or 2mA. Normally, the output is supposed to be 4-20mA. (Default setting is 2mA)</p>
	<p>➤ By default, it is set to 2mA.</p>
	<p>➤ A message "END" indicates that maintenance mode setting is completed. While "END" is being shown, press "FUNC" key. Then you will enter the menu mode.</p>

6.14. Adjustment mode setting

※  **The operation described in this section must not be allowed by general users.**

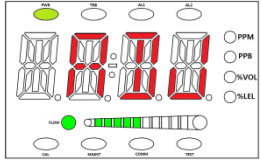
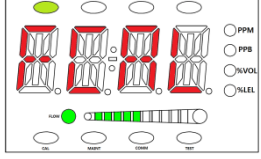
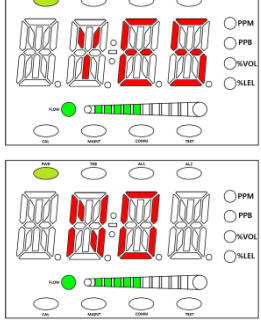
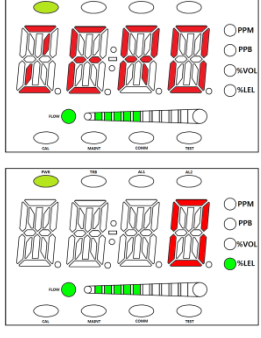
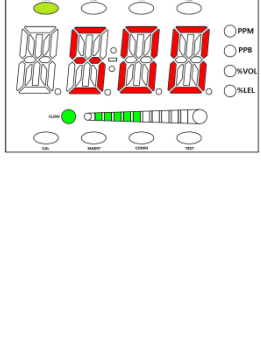
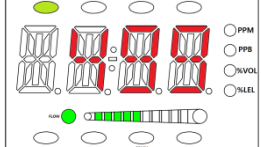
	<ul style="list-style-type: none"> ➤ If you press and hold "FUNC" key for 2 seconds or more in the gas reading state, you will enter the menu selection mode. ➤ To enter the adjustment mode, select "ADJ"(Adjustment) using Up or Down key. While "ADJ" is being displayed, press "FUNC" key.
	<ul style="list-style-type: none"> ➤ The flow calibration mode("FCAL") allows you to execute a flow calibration. Press "FUNC" key. The device will show a selection screen to choose "YES" or "NO".
	<ul style="list-style-type: none"> ➤ You can select an option using Up or Down key. ➤ Select "YES" and then press "FUNC" key. Then you will enter a flow calibration mode. If you select "NO" and press "FUNC" key, you will enter "MA-C"(mA output calibration) mode. ➤ By default, it is set to "NO".
	<ul style="list-style-type: none"> ➤ This mode allows you to set zero flow level. After "ZERO" is first displayed, pump becomes off. The flow at this moment will be displayed. After about 10 seconds later, if you press "FUNC" key, then zero flow rate is set to the value. ➔ If you need to execute calibration in an operation of pump due to residual vibration, 10 seconds of standby time is required. Without the 10 seconds of standby time, an accuracy will be affected.
	<ul style="list-style-type: none"> ➤ This mode allows you to set a span flow level. The span flow proceeds at 500cc/min. Use a flow meter to measure an actual flow. By touching Up or Down key, adjust the number on the screen to the measured flow value. While the value is being shown, press "FUNC" key. Then span flow setting is completed. The device proceeds to a flow measuring mode immediately. ➔ If you execute calibration, you need 10 seconds of standby time after turning on pump. Without the 10 seconds of standby time, an accuracy will be affected.
	<ul style="list-style-type: none"> ➤ This mode presents the current flow after flow calibration is completed. If you press "FUNC" key in this state, the device proceeds to the next mode.

	<ul style="list-style-type: none"> ➤ The mA Calibration("MA-C") mode allows you to execute a calibration for mA output. While "MA-C" is being shown, press "FUNC" key. Then you enter the mode to select "YES" or "NO".
	<ul style="list-style-type: none"> ➤ You can select one option using Up or Down key. ➤ If you select "YES" and press "FUNC" key, you will enter mA output calibration mode. ➤ By default, it is set to "NO".
	<ul style="list-style-type: none"> ➤ This is an output 4mA("oA04") mode in which you need to adjust the value. Using multimeter(tester), measure the output value. Adjust the value on the screen to be the same value as the measured output value using Up or Down key. While the desired number is being shown, press "FUNC" key.
	<ul style="list-style-type: none"> ➤ This is an output 20mA("oA20") mode in which you need to adjust the value. Using multimeter(tester), measure the output value. Adjust the value on the screen to be the same value as the measured output value using Up or Down key. While the desired number is being shown, press "FUNC" key.
	<ul style="list-style-type: none"> ➤ This mode is mA Output test mode. Adjusting the value with Up or Down key, make sure the value is same as the value measured by multimeter (tester). While the desired number is being shown, press "FUNC" key. Then the device goes to the next mode.
	<ul style="list-style-type: none"> ➤ A message "END" indicates that adjustment mode setting is completed. While "END" is being shown, press "FUNC" key. Then you will enter the gas reading mode.

7. Error & Warring Message (Troubleshooting)

7.1. Error Code

Message	Description & Condition	Misc.
E-10	Sensor cartridge is not attached or faulty.	Fault
E-11	Communication loss between the main part and sensor cartridge	Fault
E-12	No sensor exists in a sensor cartridge	Fault
E-13	24C02(EEPROM) of a sensor PCB is faulty	Fault
E-19	Zero value of a sensor is too low (Under)	Fault
E-20	Flow sensor works improperly (in case that sensor hose is replaced)	Fault
E-21	Flow rate of flow sensor is too low	Fault
E-22	Flow rate of flow sensor is too high	Fault
E-30	Current of Pyrolyzer is measured to be 50mA or less	Fault
E-31	An internal EEPROM is not recognized	Fault
E-32	Current of Pyrolyzer is measured to be 550mA or higher	Fault

[Table. Error Code]

7.2. Warning Code

Message	Description & Condition	Misc
W-01	Calibration period is expired	Warring
W-02	Sensor manufacturing date is not registered	Warring

[Table 5. Warning Code]

8. Communication Interface

8.1. 4~20mA Current output conditions

Current output	Description
Lower than 3mA	Fault Mode or Under Range(-10% or less)
3mA	Maintenance Mode
4~20mA	Normal Operation (0~100%)
21.6mA	OVER Range(110% or higher)

[Table 6. Analog 4~20mA output]

8.2. 485 MODBUS Interface

8.2.1. RS485 Communication configuration

- 1) Baud rate: 9600 bps
- 2) Data bits: 8bits
- 3) Stop bit: 1bits
- 4) Parity: Even

8.2.2. Address Structure

Category	Address	Bits	Description
Measured gas concentration	30001	BIT15~0	Measured gas concentration value (integer type / no consideration of a Decimal Point)
High Scale setting value	30002	BIT15~0	High Scale setting value (integer type / no consideration of a Decimal Point)
Primary Alarm setting value	30003	BIT15~0	Primary Alarm setting value (integer type / no consideration of a Decimal Point)
Secondary Alarm setting value	30004	BIT15~0	Secondary Alarm setting value (integer type / no consideration of a Decimal Point)
Gas detector State value	10000	BIT0	Alarm 1 Active state
		BIT1	Alarm 2 Active state
		BIT2	Fault Active state
		BIT3	Maintenance Mode state
		BIT4	Test Mode state
		BIT5	Calibration Mode state
		BIT6	Reserved
		BIT7	Toggle Bit(bit alteration in 2 sec interval)
External Test	3	BIT0~7	Gas detector Test Mode Setting
External Reset	2	BIT0~7	Gas detector Test Mode Completion

[Table 7. RS485 Address Structure]

8.3. Terminal Block Layout

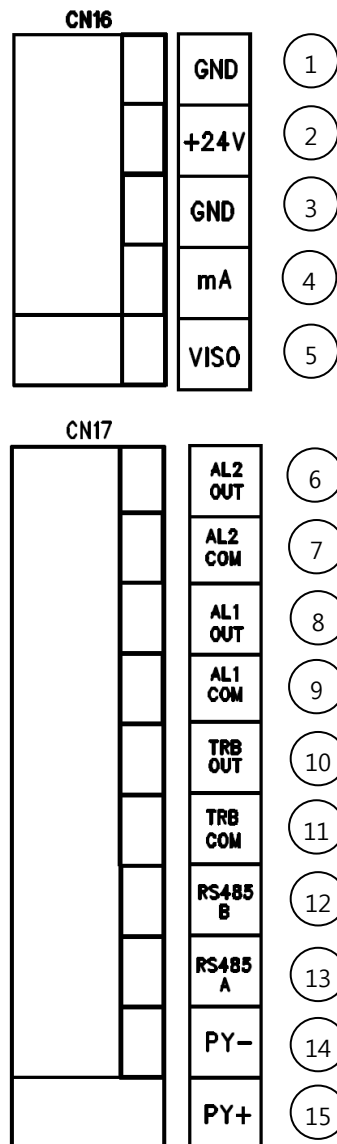

[Figure 3. Terminal Block Port Layout]

CN16		CN17	
No	Description	No	Description
①	(+) Power Terminal	⑥	ALARM2 RELAY OUTPUT port
②	(-) Power Terminal	⑦	ALARM2 RELAY Common Ground
③	4~20mA Common Ground	⑧	ALARM1 RELAY OUTPUT port
④	4~20mA Output Signal	⑨	ALARM1 RELAY Common Ground
⑤	External power supply port in case of selecting J1 SINK	⑩	TROUBLE RELAY OUTPUT port
		⑪	TROUBLE RELAY Common Ground
		⑫	RS485(B) Terminal
		⑬	RS485(A) Terminal
		⑭	Pyrolyzer (-) Terminal
		⑮	Pyrolyzer (+) Terminal

[Table 8. Terminal board port description]

8.4. Details about Terminal Board Ports

8.4.1. Power & Output Signal Terminal (CN1)

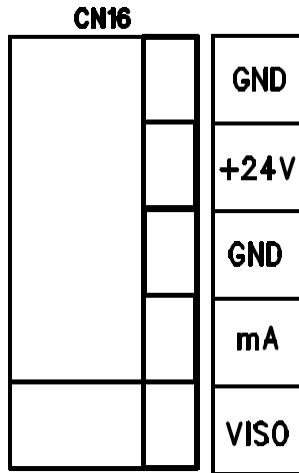

Port	Description
GND	Gas detector power GND
+24V	Gas detector DC power +24V
GND	mA and Gas detector power GND
mA	4~20mA output port
VISO	External power supply port in case of selecting J1 SINK

[Table 9. Detailed description about CN16]

8.4.1. RS485 & Relay Contact Terminal (CN17)

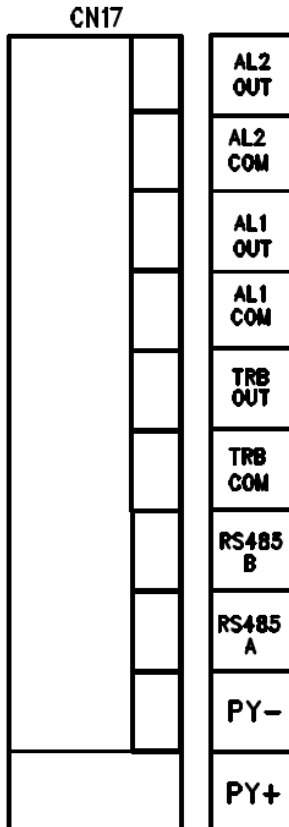

Port	Description
AL2-OUT	Alarm2 relay output port
AL2-COM	Alarm2 relay Common port
AL1-OUT	Alarm1 relay output port
AL1-COM	Alarm1 relay Common port
TRB-OUT	Trouble relay output port
TRB-COM	Trouble relay Common port
RS485B	RS485 communication B port
RS485A	RS485 communication A port
PY-	Pyrolyzer – port
PY+	Pyrolyzer +port

[Table 10. Detailed description about CN17]

9. Terminal Connection Diagram

Release a screw fixing the case cover on the front of detector. Detach the case cover from the body. Second, release two screws fixing a main sampling pump assembly. Pull this assembly forwards. Then you can see terminal PCB.

9.1. Power and 4-20mA Signal layout

If using DC24V as power, connect the power to CN16(+24V,GND).

Note 1) Must use shield cable of 1.5sq or higher.

Note 2) This function is operable only if there exists GTD5000F Analog output option.

9.1.1. Power and 4~20mA Source layout

Connect 4-20mA signal port in PLC to 'mA' in GTD-5000F. GND port is shared by power. Additionally, connect jumper-pin to J1 in main board.

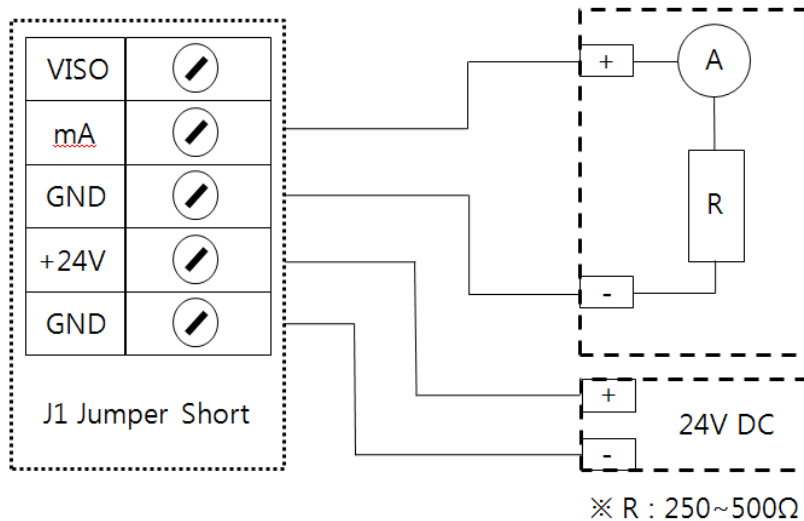

[Figure 4. 4~20mA Source Driver Layout]

9.1.2. Power and 4~20mA Sink Layout

Connect 4-20mA Sink output(+) port in PLC to E.+V port and (-) port to 'mA'. Connect J1 jumper to SINK.

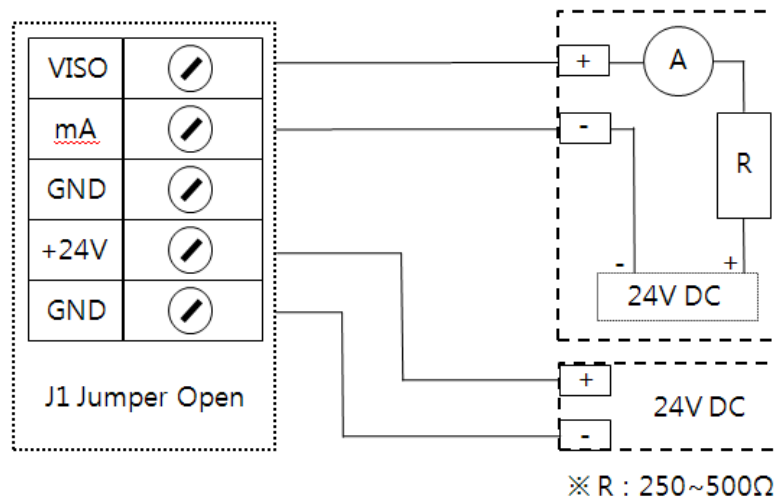

[Figure 5. 4~20mA Sink Driver Layout]

9.2. Alarm signal connection

Connect the trouble and alarm relay linked to CN17 port as following instructions.

Note 1) Relay is SPDT type and 250V /1A capable dry contact

1) Trouble Relay output layout

Port name	Fault Relay Contact	Jumper Setting
TRB-OUT	Trouble Relay normally Closed	J3 Jumper NC on
	Trouble Relay normally Open	J3 Jumper NO on
TRB-COM	Trouble Relay Common	-

2) Alarm1 Relay output layout

Port name	Fault Relay Contact	Jumper Setting
AL1-OUT	Alarm1 Relay normally Closed	J5 Jumper NC on
	Alarm1 Relay normally Open	J5 Jumper NO on
AL1-COM	Alarm1 Relay Common	-

3) Alarm2 Relay output layout

Port name	Fault Relay Contact	Jumper Setting
AL2-OUT	Alarm2 Relay normally Closed	J7 Jumper NC on
	Alarm2 Relay normally Open	J7 Jumper NO on
AL2-COM	Alarm2 Relay Common	-

9.3. RS-485 Communication Signal Connection

Connect RS-485A and RS-485B in CN17 to master ports as follows.

Port name	Master Port name	Misc.
RS485A	'TRXD+' or 'A' or 'P'	
RS485B	'TRXD-' or 'B' or 'N'	

Note 1) Use RS-485 dedicated cable.

Note 2) This function is operable only if GTD5000FF RS485 Option exists.

9.4. How to connect this device to main control of other products

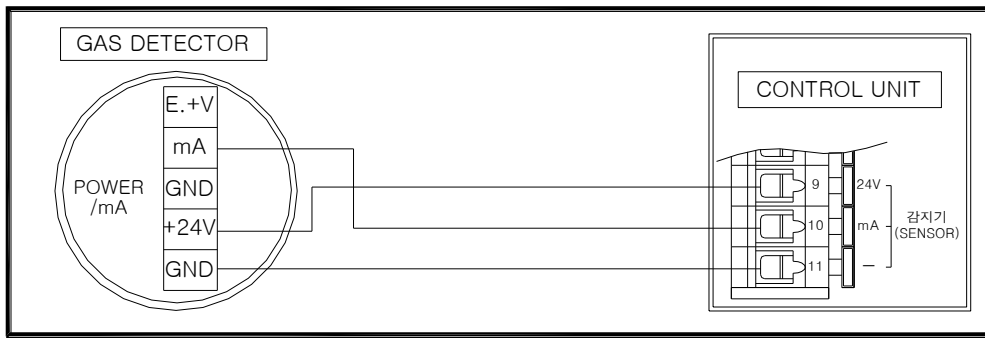

GTC-100A Series

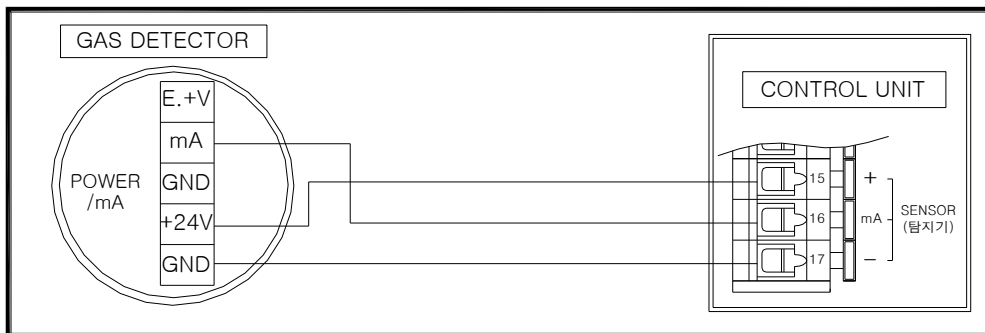

GTC-200A/210A Series

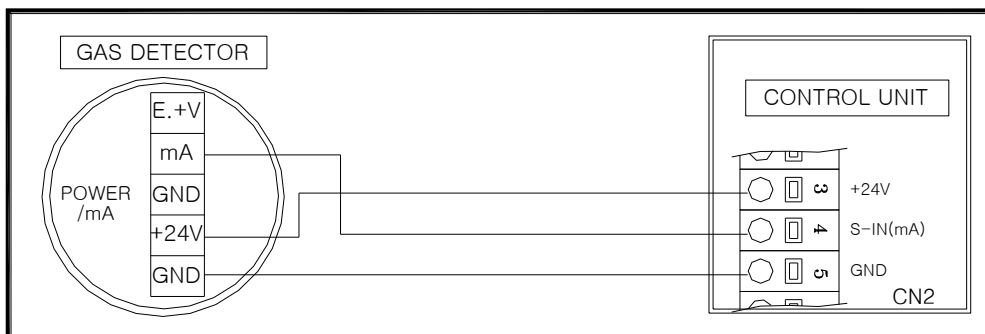

GTC-510A/520A Series

10. Appearance Drawing and Dimensions

10.1. GTD-5000F Appearance Drawing and Dimensions

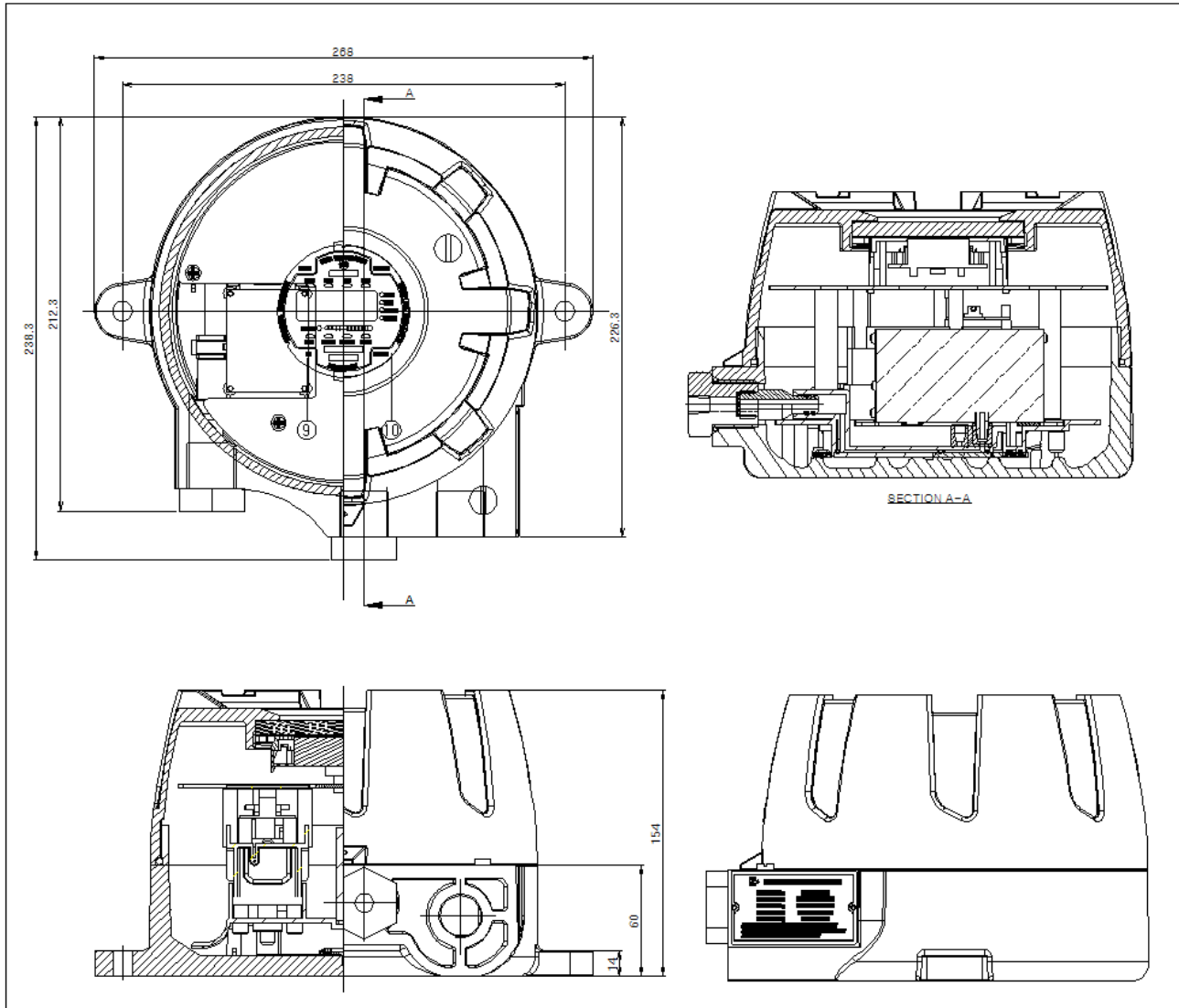

[Figure 9. GTD-5000F Appearance Drawing and Dimensions]

11. Cautions prior to Installation

11.1. Installation Site Selection (Industrial safety and health regulation)

A place to install a gas leakage detecting alarm is recommended as follows.

- 1) Chemical facilities and facilities annexed thereto, such as compressor, valve, reactor and pipe joints dealing with flammable and/or toxic material installed in and out of buildings with high probability of gas leaks.
- 2) Location where gas is prone to stay due to vicinity of manufacturing facilities with fire source such as heating device.
- 3) Joint area and vicinity thereof for filling with flammable and toxic materials.
- 4) Substation, electricity distribution station, control room and the like placed within an explosion-proof area
- 5) Other areas where gases are prone to stay.

11.2. Installation Site Selection (High Pressure Gas Safety Control Act)

Gas detector of gas leakage alarm should be installed as close as possible to a suspected area of gas leak. Exceptionally, the gas detector should be installed at one of following areas in case of the area in which ambient gas is prone to stay although no direct gas leakage is expected.

- 1) The gas leak detector installed outside of building must be positioned at an area where gas is prone to stay, taking into account of direction of wind change, wind speed, gas specific gravity and the like.
- 2) The gas leak detector installed inside of building must be positioned at a lower part of the building if specific gravity of gas to be detected is heavier than that of air, and at a higher part of the building or close to ventilation if specific gravity of gas to be detected is lighter than that of air.
- 3) The alarm of gas leak detector must be installed at an area where the detector is mounted and where staffs are available at all the times.

11.3. Cautions on installation

The gas detector must be installed at water-free area to avoid electrical problems caused by water such as a raindrop because the sensor part is not a fully closed structure. If water permeates into the sensor part, the gas detector may be malfunctioned. If necessary, the use of supplementary equipment such as a rain cover will be helpful to avoid that kind of problem.

- 1) Do not install the gas detector where vibration or shock may occur.
Vibration or shock can affect the output values.
- 2) Do not install the gas detector where temperature and/or humidity may get high.
High temperature and/or humidity can cause malfunction of the device.
- 3) Do not install the gas detector where an electronic noise may occur.
Please avoid an area near high frequency or high voltage as far as possible. (For example, in vicinity of motor, pump and high voltage cable etc)
- 4) Install the gas detector where it is easy to access for maintenance. Periodic maintenance and calibration are required. Avoid inconvenient locations when maintenance is carried out.

11.4. Cable Wiring

For preventing undesired influence by external noise, we recommend to use shield type cable. In addition, for preventing the device from damage upon impact, we recommend to use cable duct, conduct pipe and flexible and so on. It is recommended that making connection between cables be avoided. However, if inevitable, we recommend junction box be used when cables are connected.

In case of inner pressure-resistant packing method applied, please use the cable of which outer diameter is suitable for inner packing size and tightly fasten the cable gland in order not to cause any inflow of gas or flame.

When explosion proof metal piping, install sealing fitting and fill it with compound after completing piping work, in order to prevent any flow of flame caused by explosion or gas inside of metal pipe. All other connecting and combining parts should be water-proof.

12. Ordering Information

GAS NAME		MESURING RANGE	TLV-TWA
Acetic Acid	CH ₃ COOH	0 ~ 30 ppm	10 ppm
Ammonia	NH ₃	0 ~ 75 ppm	25 ppm
Antimony Pentachloride	SbCl ₅	0 ~ 15 ppm	5 ppm
Arsetic Tafluoride	AsF ₃	0 ~ 9 ppm	3 ppm
Arsetic Pentafluoride	AsF ₅	0 ~ 9 ppm	3 ppm
Arsenic Tfchloride	AsCl ₃	0 ~ 15 ppm	5 ppm
Arsenic Pentachloride	AsCl ₅	0 ~ 15 ppm	5 ppm
Arsine	AsH ₃	0 ~ 0.3 ppm	0.05 ppm
Boron Trichloride	BCl ₃	0 ~ 15 ppm	5 ppm
Boron Tribromide	BBr ₃	0 ~ 9 ppm	3 ppm
Boron Trifluoride	BF ₃	0 ~ 9 ppm	3 ppm
Bromine	Br ₂	0 ~ 1 ppm	0.1 ppm
Chlorine	Cl ₂	0 ~ 3 ppm	1 ppm
Carbon Tetrachloride	CCl ₄	0 ~ 30 ppm	5 ppm
Carbon Monoxide	CO	0 ~ 150 ppm	25 ppm
Chlorine Tetrafluoride	ClF ₃	0 ~ 1 ppm	0.1 ppm
Diborane	B ₂ F ₆	0 ~ 0.3 ppm	0.1 ppm
Dichlorosilane	SiH ₂ Cl ₂	0 ~ 15 ppm	5 ppm
Disilane	Si ₂ H ₆	0 ~ 15 ppm	5 ppm
Ethylene Oxide	C ₂ H ₄ O	0~30ppm	1ppm
Fluorine	F ₂	0 ~ 3 ppm	1 ppm
Germane	GeH ₄	0 ~ 2 ppm	0.2 ppm
Germanium Tetrachloride	GeCl ₄	0 ~ 15 ppm	5 ppm
Hydrazine	N ₂ H ₄	0 ~ 10 ppm	0.01 ppm
Hydrogen	H ₂	0 ~ 2000 ppm	LEL=4%VOL
Hydrogen Bromide	HBr	0 ~ 9 ppm	3 ppm
Hydrogen Chloride	HCl	0 ~ 15 ppm	5 ppm
Hydrogen Cyanide	HCN	0 ~ 30 ppm	10 ppm
Hydrogen Fluoride	HF	0 ~ 9 ppm	3 ppm
Hydrogen Iodine	HI	0 ~ 5 ppm	2 ppm
Hydrogen Selenide	H ₂ Se	0 ~ 0.2 ppm	0.05 ppm
Hydrogen Sulfide	H ₂ S	0 ~ 30 ppm	10 ppm
Iodine	I ₂	0 ~ 1 ppm	0.1 ppm
Isopropyl Alcohol(IPA)	CH ₃ CHOHCH ₃	0 ~ 2000 ppm	400 ppm
Molybdenum Fluoride	MoF ₆	0 ~ 9 ppm	3 ppm
Nitric Acid	HNO ₃	0 ~ 20 ppm	2 ppm
Nitrogen Monoxide	NO	0 ~ 100 ppm	25 ppm
Nitrogen Dioxide	NO ₂	0 ~ 15 ppm	3 ppm
Nitrogen Trifluoride	NF ₃	0 ~ 30 ppm	10 ppm
Nitrogen Tetraoxide	N ₂ O ₄	0 ~ 15 ppm	3 ppm
Oxygen	O ₂	0 ~ 25% Volume	-
Ozone	O ₃	0 ~ 1 ppm	0.1 ppm

GAS NAME		MESURING RANGE	TLV-TWA
Phosgene	COCl_2	0 ~ 0.3 ppm	0.1 ppm
Phosphine	PH_3	0 ~ 1 ppm	0.3 ppm
Phosphorus Oxychloride	POCl_3	0 ~ 15 ppm	5 ppm
Phosphorus Pentafluoride	PF_5	0 ~ 9 ppm	3 ppm
Phosphorus Trichloride	PCl_3	0 ~ 15 ppm	5 ppm
Silane	SiH_4	0 ~ 15 ppm	5 ppm
Silicon Tetrachloride	SiCl_4	0 ~ 15 ppm	5 ppm
Silicon Tetrafluoride	SiF_4	0 ~ 9 ppm	3 ppm
Sulfur Dioxide	SO_2	0 ~ 10 ppm	2 ppm
Sulfur Tetrafluoride	SF_4	0 ~ 9 ppm	3 ppm
Sulfur Hexafluoride	SF_6	0 ~ 2000 ppm	
Tantalum Fluoride	TaF_5	0 ~ 9 ppm	3 ppm
Tetraethyl Orthosilicate	TEOS	0 ~ 15 ppm	10 ppm
Tin Tetrachloride	SnCl_4	0 ~ 15 ppm	5 ppm
Titanium Fluoride	TiF_4	0 ~ 9 ppm	3 ppm
Titanium Tetrachloride	TiCl_4	0 ~ 15 ppm	5 ppm
Trichlorosilane	SiHCl_3	0 ~ 15 ppm	5 ppm
Trimethoxy Phosphate	$\text{P}(\text{OCH}_3)_3$	0 ~ 15 ppm	2 ppm
Tungsten Hexafluoride	WF_6	0 ~ 9 ppm	3 ppm

13. Revision history

Version	Contents	Date
Rev. 0	Initial creation of this manual	March 28, 2013
Rev. 1	Produced a separate document of Catridge/IR type manual	October 22, 2013
Rev. 2	Updated the drawings in the manual	December 11, 2013
Rev. 3	Revised a typing error	March 17, 2014
Rev. 4	Revise of version display part F-CT menu is added and the set value is changed	June 04, 2014
END		

This product and this instruction manual can be revised for performance improvement and users' convenience without prior notice.



GASTRON Co., LTD

18-8, Dogeumdanji 1-gil (Palgok 2-dong),
Sangrok-gu, Ansan-si, Gyeonggi-do, Korea

Tel : 031-490-0800
<http://www.gastron.com>

Fax : 031-490-0801
gastron@gastron.com